

EMC TEST REPORT

The device described below is tested by Dongguan Nore Testing Center Co., Ltd. to determine the maximum emission levels emanating from the device, the severe levels which the device can endure and E.U.T.'s performance criterion. The test results are contained in this test report. Dongguan Nore Testing Center Co., Ltd. is assumed of full responsibility for the accuracy and completeness of these tests.

Applicant : Flin Technologies Private Limited
Address : 1601 Montreal Tower, Shastri Nagar, Andheri West, Mumbai - 400 053, India
Manufacturer/ Factory : Flin Technologies Private Limited
Address : 1601 Montreal Tower, Shastri Nagar, Andheri West, Mumbai - 400 053, India
E.U.T. : FlinInfini Lite On-grid Inverter with Energy storage
Brand Name : 
Model No. : FlinInfini Lite 2kW-24V, FlinInfini Lite 1kW-12V
Measurement Standard : EN 61000-6-4: 2007+A1: 2011
EN 61000-3-2: 2014, EN 61000-3-3: 2013
EN 61000-6-2: 2005+AC: 2005
(EN 61000-4-2: 2009, EN 61000-4-3: 2006+A2: 2010,
EN 61000-4-4: 2012, EN 61000-4-5: 2014,
EN 61000-4-6: 2014, EN 61000-4-11: 2004, EN 61000-4-8: 2010)
Date of Receiver : September 14, 2016
Date of Test : September 14, 2016 to September 20, 2016
Date of Report : September 21, 2016

This Test Report is Issued Under the Authority of :

Prepared by



Yoyo Deng / Engineer



Approved & Authorized Signer



Iori Fan / Authorized Signatory

This report shows that the E.U.T. is technically compliant with the EN 61000-6-4, EN 61000-3-2, EN 61000-3-3 and EN 61000-6-2. This report applies to above tested sample only and shall not be reproduced in part without written approval of Dongguan Nore Testing Center Co., Ltd.

TABLE OF CONTENTS

1. SUMMARY OF TEST RESULTS.....	6
2. GENERAL INFORMATION.....	7
2.1 Details of E.U.T.....	7
2.2 Description of Support Device.....	7
2.3 Block Diagram of Test Setup.....	9
2.4 Test Facility.....	9
2.5 Abnormalities from Standard Conditions.....	9
3. MEASURING DEVICES AND TEST EQUIPMENT.....	10
3.1. For Mains terminals Disturbance voltage Test.....	10
3.2. For Radiated Emission Measurement.....	10
3.3. For Harmonic/ Flicker Measurement.....	10
3.4. For Electrostatic Discharge Immunity Test.....	11
3.5. For RF Electromagnetic Field Immunity Test.....	11
3.6. For Electrical Fast Transient /Burst Immunity Test.....	11
3.7. For Surge Immunity Test.....	11
3.8. For Injected Currents Immunity Measurement.....	11
3.9. For Voltage Dips and Interruptions Measurement.....	12
3.10. For Magnetic Field Immunity Measurement.....	12
4. MAINS TERMINAL DISTURBANCE VOLTAGE MEASUREMENT.....	13
4.1 Block Diagram of Test Setup.....	13
4.2 Limit of Mains Terminal Disturbance voltage measurement.....	13
4.3 Test Procedure.....	14
4.4 Operating Condition of E.U.T.....	14
4.5 Mains Terminal Disturbance Voltage Test Results.....	14
5. RADIATED EMISSION MEASUREMENT.....	27
5.1 Block Diagram of Test.....	27
5.2 Limit of Radiated Emission Measurement.....	27
5.3 Test Procedure.....	28
5.4 Operating Condition of E.U.T.....	28
5.5 Radiated Emission Measurement Result.....	28
6. HARMONIC CURRENT EMISSION TEST.....	41
6.1 Block Diagram of Test Setup.....	41
6.2 Limits of Harmonics current measurement.....	41
6.3 Test Procedure.....	42
6.4 Operating Condition of E.U.T.....	42
6.5 Harmonics Current Measurement Result.....	42
7. VOLTAGE FLUCTUATIONS & FLICKER TEST.....	49
7.1 Block Diagram of Test Setup.....	49
7.2 Limits of Voltage Fluctuations & Flicker Measurement.....	49
7.3 Test Procedure.....	49
7.4 Operating Condition of E.U.T.....	50
7.5 Test Results.....	50
8. PERFORMANCE CRITERIA FOR IMMUNITY.....	53
9. ELECTROSTATIC DISCHARGE TEST.....	54

9.1 Block Diagram of Test Setup.....	54
9.2 Test Standard and Severity Levels.....	54
9.3 Test Procedure.....	55
9.4 Test Results.....	55
10. RF FIELD STRENGTH SUSCEPTIBILITY TEST.....	57
10.1 Block Diagram of Test Setup.....	57
10.2 Test Standard and Severity Levels.....	57
10.3 Test Procedure.....	58
10.4 Test Results.....	58
11. ELECTRICAL FAST TRANSIENT/BURST TEST.....	60
11.1 Block Diagram of Test Setup.....	60
11.2 Test Standard and Severity Levels.....	60
11.3 Test Procedure.....	61
11.4 Test Result.....	61
12. SURGE IMMUNITY TEST.....	63
12.1 Block Diagram of Test Setup.....	63
12.2 Test Standard and Severity Levels.....	63
12.3 Test Procedure.....	63
12.4 Test Result.....	64
13. INJECTED CURRENTS SUSCEPTIBILITY TEST.....	66
13.1 Block Diagram of Test Setup.....	66
13.2 Test Standard and Severity Levels.....	66
13.3 Test Procedure.....	67
13.4 Test Result.....	67
14. VOLTAGE DIPS AND INTERRUPTIONS TEST.....	69
14.1 Block Diagram of Test Setup.....	69
14.2 Test Standard and Severity Levels.....	69
14.3 Test Procedure.....	69
14.4 Test Result.....	70
15. MAGNETIC FIELD IMMUNITY TEST.....	72
15.1 Block Diagram of Test Setup.....	72
15.2 Test Standard and Severity Levels.....	72
15.3 Test Procedure.....	72
15.4 Test Result.....	73
16. PHOTOGRAPH.....	75
16.1 Photo of Conducted Emission Measurement.....	75
16.2 Photo of Conducted Emission Measurement.....	75
16.3 Photo of Radiation Emission Measurement.....	76
16.4 Photo of Radiation Emission Measurement.....	76
16.5 Photo of Harmonic/Flicker Measurement.....	77
16.6 Photo of Harmonic/Flicker Measurement.....	77
16.7 Photo of Electrostatic Discharge Test.....	78
16.8 Photo of Electrostatic Discharge Test.....	78
16.9 Photo of Electrical Fast Transient /Surge /Voltage Dips Test.....	79
16.10 Photo of Electrical Fast Transient /Surge /Voltage Dips Test.....	79

Appendix I (Photos of E.U.T.) (15 pages)

1. SUMMARY OF TEST RESULTS

The E.U.T. has been tested according to the following specifications:

EMISSION			
Standard	Test Type	Result	Remarks
EN 61000-6-4: 2007+A1: 2011	Mains Terminal Disturbance Voltage Test	PASS	Uncertainty: 2.7dB
	Radiated Emission Test	PASS	Uncertainty: 3.4dB
EN 61000-3-2: 2014	Harmonic current emission	PASS	Meets the requirements.
EN 61000-3-3: 2013	Voltage fluctuations & flicker	PASS	Meets the requirements.

IMMUNITY (EN 61000-6-2: 2005+AC: 2005)			
Standard	Test Type	Result	Remarks
EN 61000-4-2: 2009	Electrostatic discharge immunity test	PASS	Meets the requirements of Performance Criterion B
EN 61000-4-3: 2006+A2: 2010	Radio-frequency, electromagnetic field immunity test	PASS	Meets the requirements of Performance Criterion A
EN 61000-4-4: 2012	Electrical fast transient/ burst immunity test	PASS	Meets the requirements of Performance Criterion B
EN 61000-4-5: 2014	Surge immunity test	PASS	Meets the requirements of Performance Criterion B
EN 61000-4-6: 2014	Injected Currents immunity test	PASS	Meets the requirements of Performance Criterion A
EN 61000-4-11: 2004	Voltage Dips and Interruptions	PASS	Meets the requirements of Performance Criterion B&C
EN 61000-4-8: 2010	Magnetic Field Immunity Test	PASS	Meets the requirements of Performance Criterion A

2. GENERAL INFORMATION

2.1 Details of E.U.T.

E.U.T.	: FlinInfini Lite On-grid Inverter with Energy storage
Model No.	: FlinInfini Lite 1kW-12V, FlinInfini Lite 2kW-24V
Brand Name	: 
Rating	: Details refer to page 7
Test Voltage	: GRID INPUT: 230V/50Hz; BATTERY: DC 12V or DC 24V; PV INPUT: DC 72V
Cable	: N/A
Description of model difference	: Both of models have the same circuit schematic, construction and critical components. Their difference in model name, input current and output power.
Remark	: None

2.2 Description of Support Device

None

Rating:

Model Name: FlinInfini Lite 2kW-24V

ModelNo. : <u>FlinInfiniLite 2kW-24V</u>	
Serial No. :  96111512100001	
PV INPUT	Nominal operating voltage 60Vdc
	<u>Vmax PV</u> 145Vdc
	PV input voltage range 30-145Vdc
	<u>Isc PV</u> 80A
	MPPT voltage range 30 ~ 115Vdc
GRID/AC OUTPUT	Nominal operating voltage 230 Vac
	Nominal output current 8.7A
	Nominal operating frequency 50Hz/60Hz
	Maximum power 2000W
	Power factor range 0.9 lead-0.9lag
AC INPUT	Nominal operating voltage 230Vac
	Maximum input current 20A
	Nominal operating frequency 50Hz/60Hz
BATTERY	Battery voltage range 20.4~30Vdc
	Maximum battery current 140A

Model Name: FlinInfini Lite 1kW-12V

ModelNo. : <u>FlinInfiniLite 1kW-12V</u>	
Serial No. :  96111512100001	
PV INPUT	Nominal operating voltage 30Vdc
	<u>Vmax PV</u> 145Vdc
	PV input voltage range 15-145Vdc
	<u>Isc PV</u> 80A
	MPPT voltage range 15 ~ 115Vdc
GRID/AC OUTPUT	Nominal operating voltage 230 Vac
	Nominal output current 4.3A
	Nominal operating frequency 50Hz/60Hz
	Maximum power 1000W
	Power factor range 0.9 lead-0.9lag
AC INPUT	Nominal operating voltage 230Vac
	Maximum input current 10A
	Nominal operating frequency 50Hz/60Hz
BATTERY	Battery voltage range 10.2 ~ 15.0Vdc
	Maximum battery current 140A

2.3 Block Diagram of Test Setup

Block diagram of connection between the E.U.T. and simulators

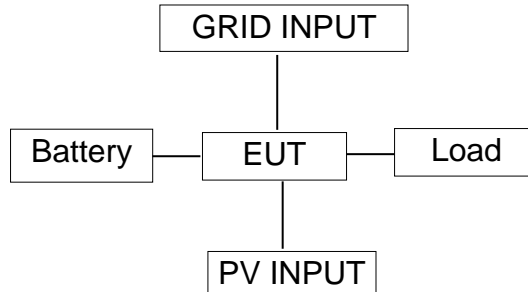

2.4 Test Facility

Site Description

EMC Lab

: Listed by CNAS, August 14, 2015
The certificate is valid until August 13, 2018
The Laboratory has been assessed and proved to be in compliance with CNAS/CL01
The Certificate Registration Number is L5795.

Listed by FCC, August. 02, 2011
The Certificate Number is 665078.

Listed by Industry Canada, July 01, 2011
The Certificate Registration Number. Is 46405-9743

Name of Firm

: Dongguan Nore Testing Center Co., Ltd.
(Dongguan NTC Co., Ltd.)

Site Location

: Building D, Gaosheng Science & Technology Park,
Zhoushi Longxi Road, Nancheng District,
Dongguan City, Guangdong Province, China

2.5 Abnormalities from Standard Conditions

None

3. MEASURING DEVICES AND TEST EQUIPMENT

3.1. For Mains terminals Disturbance voltage Test

Item	Equipment	Manufacturer	Model No.	Serial No.	Last Cal.	Cal. Interval
1.	Test Receiver	Rohde & Schwarz	ESCI	101152	Mar. 07, 2016	1 Year
2.	L.I.S.N	Rohde & Schwarz	ENV 216	101317	Mar. 07, 2016	1 Year
3.	L.I.S.N	Schwarzbeck	NNLK8129	8129-212	Mar. 07, 2016	1 Year
4.	RF Switching Unit	Compliance Direction Systems Inc.	RSU-M2	38311	Mar. 07, 2016	1 Year
5.	Pulse Limiter	MTS-systemtechnik	MTS-IMP-136	26115-010-0007	Mar. 07, 2016	1 Year

3.2. For Radiated Emission Measurement

Item	Equipment	Manufacturer	Model No.	Serial No.	Last Cal.	Cal. Interval
1.	Test Receiver	Rohde & Schwarz	ESCI7	100837	Mar. 07, 2016	1 Year
2.	Antenna	Schwarzbeck	VULB9162	9162-010	Mar. 14, 2016	1 Year
3.	Positioning Controller	UC	UC 3000	N/A	N/A	N/A
4.	Color Monitor	SUNSP0	SP-140A	N/A	N/A	N/A
5.	Single Phase Power Line Filter	SAEMC	PF201A-32	110210	N/A	N/A
6.	3 Phase Power Line Filter	SAEMC	PF401A-200	110318	N/A	N/A
7.	DC Power Filter	SAEMC	PF301A-200	110245	N/A	N/A
8.	Cable	Huber+Suhner	CBL3-NN-9M	21490001	Mar. 07, 2016	1 Year
9.	Cable	Huber+Suhner	RG223U	N/A	Mar. 07, 2016	1 Year
10.	Power Amplifier	HP	HP 8447D	1145A00203	Mar. 07, 2016	1 Year

3.3. For Harmonic/ Flicker Measurement

Item	Equipment	Manufacturer	Model No.	Serial No.	Last Cal.	Cal. Interval
1.	Three Phase Harmonic Flicker Test System	California Instruments	MX45-3PI-400-413-C TSHL-LF-SNK	1424A00547	Jul. 25, 2016	1 Year

3.4. For Electrostatic Discharge Immunity Test

Item	Equipment	Manufacturer	Model No.	Serial No.	Last Cal.	Cal. Interval
1.	ESD Tester	TESEQ	NSG 437	432	Mar. 14, 2016	1 Year

3.5. For RF Electromagnetic Field Immunity Test

Item	Equipment	Manufacturer	Model No.	Serial No.	Last Cal.	Cal. Interval
1.	Signal Generator	Agilent	N5181A	MY50142530	Aug. 31, 2016	1 Year
2.	Antenna	Schwarzbeck	VULB9162	9162-010	Mar. 14, 2016	1 Year
3.	RF Power Meter	ESE	4242	13984	Aug. 31, 2016	1 Year
4.	Power Amplifier	TESEQ	CBA 1G-150	T44029	N/A	1 Year
5.	Power Sensor	ESE	51011EMC	35716	Aug. 31, 2016	1 Year

3.6. For Electrical Fast Transient /Burst Immunity Test

Item	Equipment	Manufacturer	Model No.	Serial No.	Last Cal.	Cal. Interval
1.	Burst Tester	EM TEST	UCS 500N	V1104108683	Mar. 07, 2016	1 Year
2.	Coupling Clamp	EM TEST	HFK	0311-94	Mar. 07, 2016	1 Year
3.	Test Soft	EM TEST	lec. control	N/A	N/A	N/A

3.7. For Surge Immunity Test

Item	Equipment	Manufacturer	Model No.	Serial No.	Last Cal.	Cal. Interval
1.	Surge Tester	EM TEST	UCS 500N	V1104108683	Mar. 07, 2016	1 Year
2.	Test Soft	EM TEST	lec. control	N/A	N/A	N/A

3.8. For Injected Currents Immunity Measurement

Item	Equipment	Manufacturer	Model No.	Serial No.	Last Cal.	Cal. Interval
1.	CDN	Luthi	L-801M2/M3	2015	Oct.19, 2015	1 Year
2.	C/S Test System	HAEFELY	WinPAMP	NSEMC002	N/A	1 Year

3.9.For Voltage Dips and Interruptions Measurement

Item	Equipment	Manufacturer	Model No.	Serial No.	Last Cal.	Cal. Interval
1.	Dips Tester	EM TEST	UCS500N	V1104108683	Mar. 07, 2016	1 Year
2.	Test Soft	EM TEST	lec.control	N/A	N/A	N/A
3.	Dips Modulator	EM TEST	V4780S2	0111-11	Mar. 07, 2016	1 Year

3.10.For Magnetic Field Immunity Measurement

(GUANGZHOU GRG METROLOGY & TEST CO., LTD.)

Item	Equipment	Manufacturer	Model No.	Serial No.	Last Cal.	Cal. Interval
1.	Magnetic Field Tester	EMC PARTNER	TRA2000	853	Jun. 1, 2016	1 Year
2.	Variac Module	EMC PARTNER	VAR-EXT10000	041	Apr. 16, 2016	1 Year
3.	Induction Coil	EMC PARTNER	MF1000-1	150	Apr. 16, 2016	1 Year

4. MAINS TERMINAL DISTURBANCE VOLTAGE MEASUREMENT

4.1 Block Diagram of Test Setup

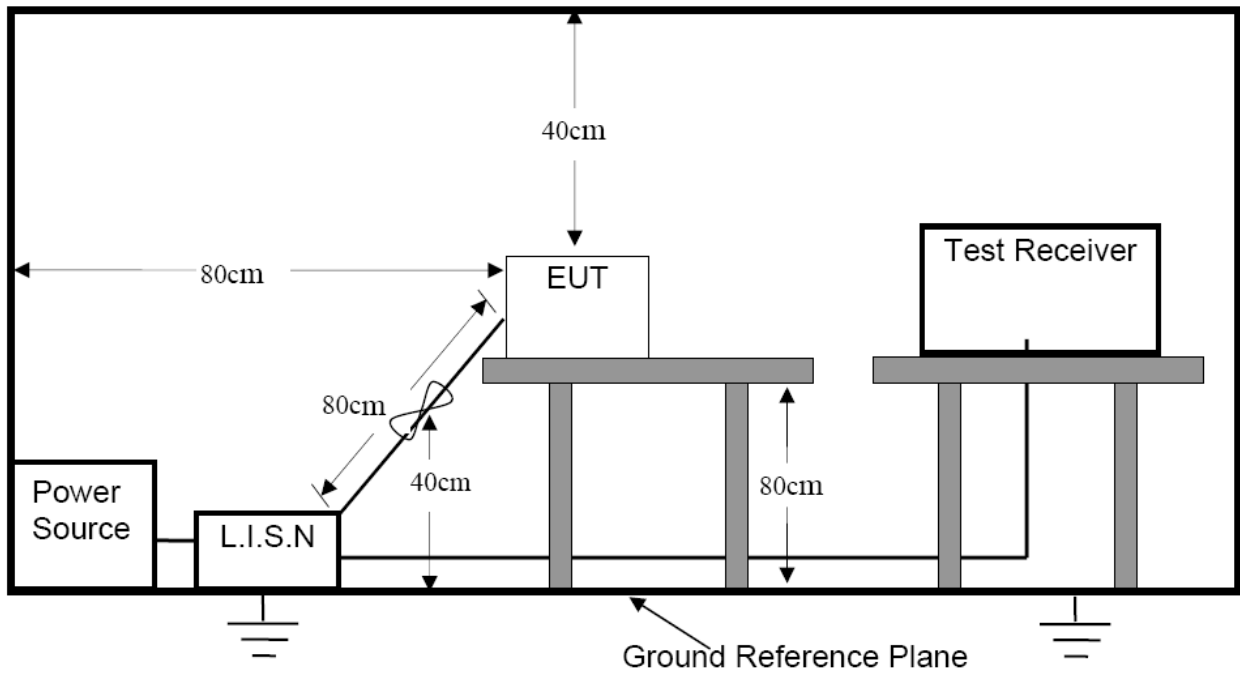

4.2 Limit of Mains Terminal Disturbance voltage measurement

Test Standard: EN 61000-6-4

Limits for conducted disturbance at the mains port.

Frequency range (MHz)	Limits (dB(uV))	
	Quasi-peak	Average
0.15 to 0.50	79	66
0.50 to 30	73	60

- Note:
1. The lower limit shall apply at the transition frequencies.
 2. The limit decreases linearly with the logarithm of the frequency in the range 0.15 MHz to 0.5 MHz.

4.3 Test Procedure

The E.U.T. is put on the 0.8 m high table and connected to the AC mains through a Artificial Mains Network (AMN). This provided a 50ohm coupling impedance for the tested equipments. Both sides of AC line are checked to find out the maximum conducted emission levels according to the EN 61000-6-4 regulations during conducted emission test.

The bandwidth of the test receiver (R&S Test Receiver ESCI) is set at 9 KHz.

4.4 Operating Condition of E.U.T.

4.4.1 Setup the E.U.T. and simulators as shown in Section 2.3.

4.4.2 Turn on the power of all equipments.

4.4.3 Let the E.U.T. work in test mode and test it.

4.5 Mains Terminal Disturbance Voltage Test Results

PASS.

Please refer to the following pages.

E.U.T :	FlinInfini Lite On-grid Inverter with Energy storage	Model Name :	FlinInfini Lite 2kW-24V
Temperature :	26 °C	Relative Humidity :	55 %
Pressure :	1006 hPa	Test Voltage :	DC 24V
Test Mode :	Stored Energy operation mode	Phase:	Line

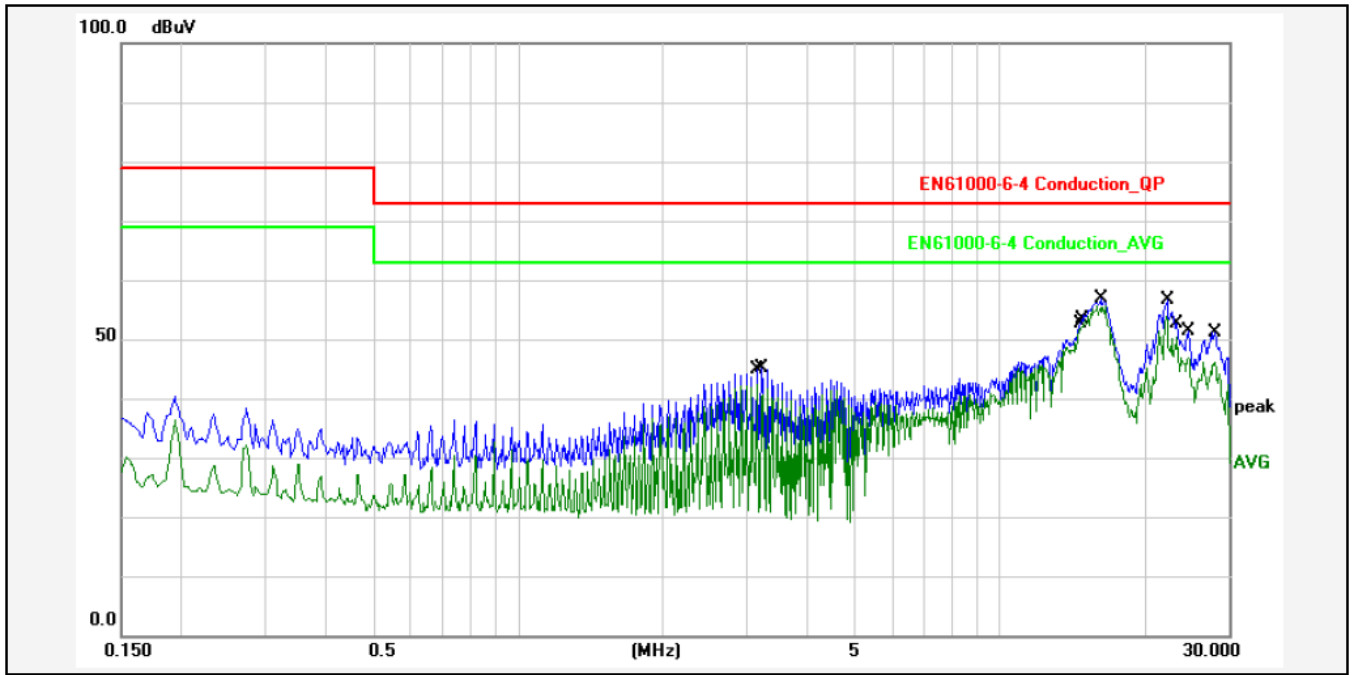

No.	Frequency (MHz)	Factor (dB)	Reading (dBuV)	Level (dBuV)	Limit (dBuV)	Margin (dB)	Detector	P/F	Remark
1	3.1460	10.56	31.89	42.45	63.00	-20.55	AVG	P	
2	3.2220	10.56	34.65	45.21	73.00	-27.79	QP	P	
3	14.5659	10.64	40.29	50.93	73.00	-22.07	QP	P	
4	14.6419	10.64	41.09	51.73	63.00	-11.27	AVG	P	
5	16.0419	10.64	45.03	55.67	63.00	-7.33	AVG	P	
6	16.2739	10.64	46.24	56.88	73.00	-16.12	QP	P	
7	22.2220	10.73	43.05	53.78	63.00	-9.22	AVG	P	
8	22.2979	10.73	45.84	56.57	73.00	-16.43	QP	P	
9	23.5380	10.76	36.50	47.26	63.00	-15.74	AVG	P	
10	24.7060	10.79	40.66	51.45	73.00	-21.55	QP	P	
11	28.0860	10.83	40.39	51.22	73.00	-21.78	QP	P	
12	28.0860	10.83	35.41	46.24	63.00	-16.76	AVG	P	

E.U.T :	FlinInfini Lite On-grid Inverter with Energy storage	Model Name :	FlinInfini Lite 2kW-24V
Temperature :	26 °C	Relative Humidity :	55 %
Pressure :	1006 hPa	Test Voltage :	DC 24V
Test Mode :	Stored Energy operation mode	Phase:	Neutral

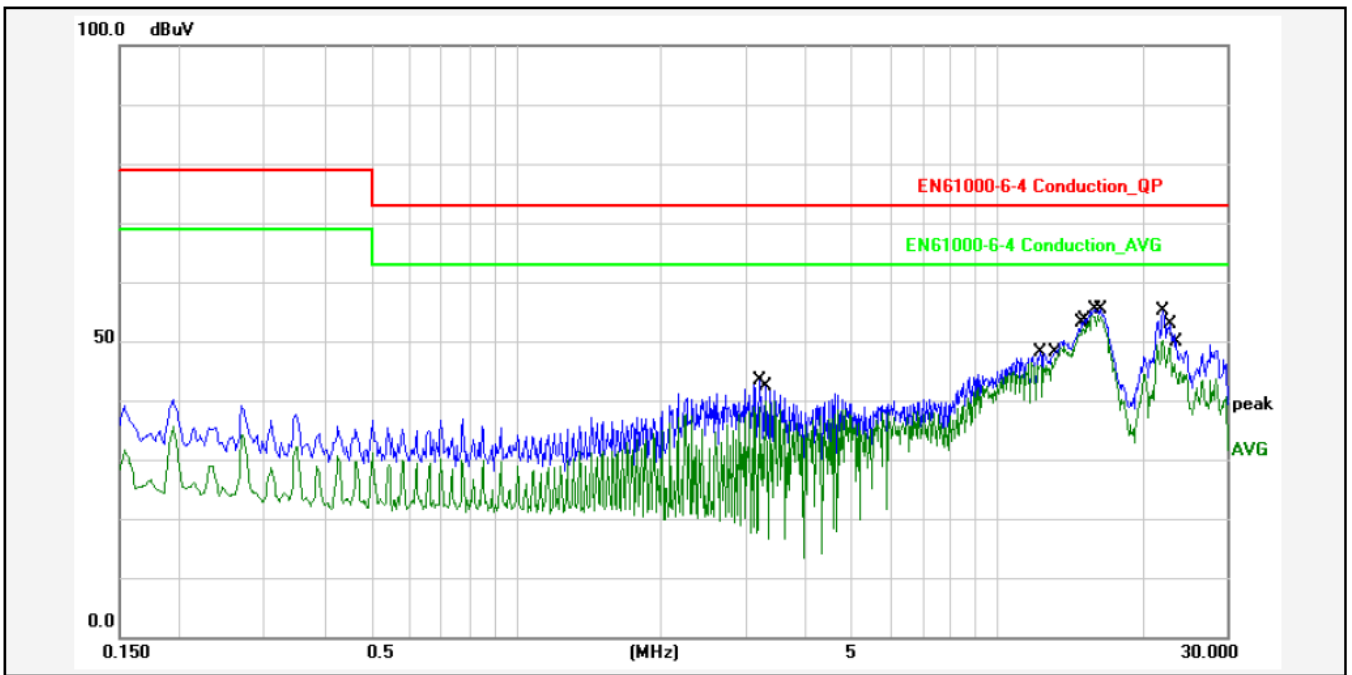

No.	Frequency (MHz)	Factor (dB)	Reading (dBuV)	Level (dBuV)	Limit (dBuV)	Margin (dB)	Detector	P/F	Remark
1	3.2179	10.56	32.71	43.27	73.00	-29.73	QP	P	
2	3.2940	10.56	29.41	39.97	63.00	-23.03	AVG	P	
3	12.2979	10.57	37.49	48.06	73.00	-24.94	QP	P	
4	12.9978	10.59	35.72	46.31	63.00	-16.69	AVG	P	
5	14.7819	10.64	41.48	52.12	73.00	-20.88	QP	P	
6	15.0938	10.64	41.42	52.06	63.00	-10.94	AVG	P	
7	15.9498	10.64	44.66	55.30	73.00	-17.70	QP	P	
8	16.1818	10.64	43.77	54.41	63.00	-8.59	AVG	P	
9	22.1219	10.73	44.32	55.05	73.00	-17.95	QP	P	
10	22.1219	10.73	39.48	50.21	63.00	-12.79	AVG	P	
11	22.6700	10.76	38.23	48.99	63.00	-14.01	AVG	P	
12	23.5219	10.76	39.07	49.83	73.00	-23.17	QP	P	

E.U.T :	FlinInfini Lite On-grid Inverter with Energy storage	Model Name :	FlinInfini Lite 2kW-24V
Temperature :	26 °C	Relative Humidity :	55 %
Pressure :	1006 hPa	Test Voltage :	AC 230V/50Hz
Test Mode :	Normal operation mode	Phase:	Line

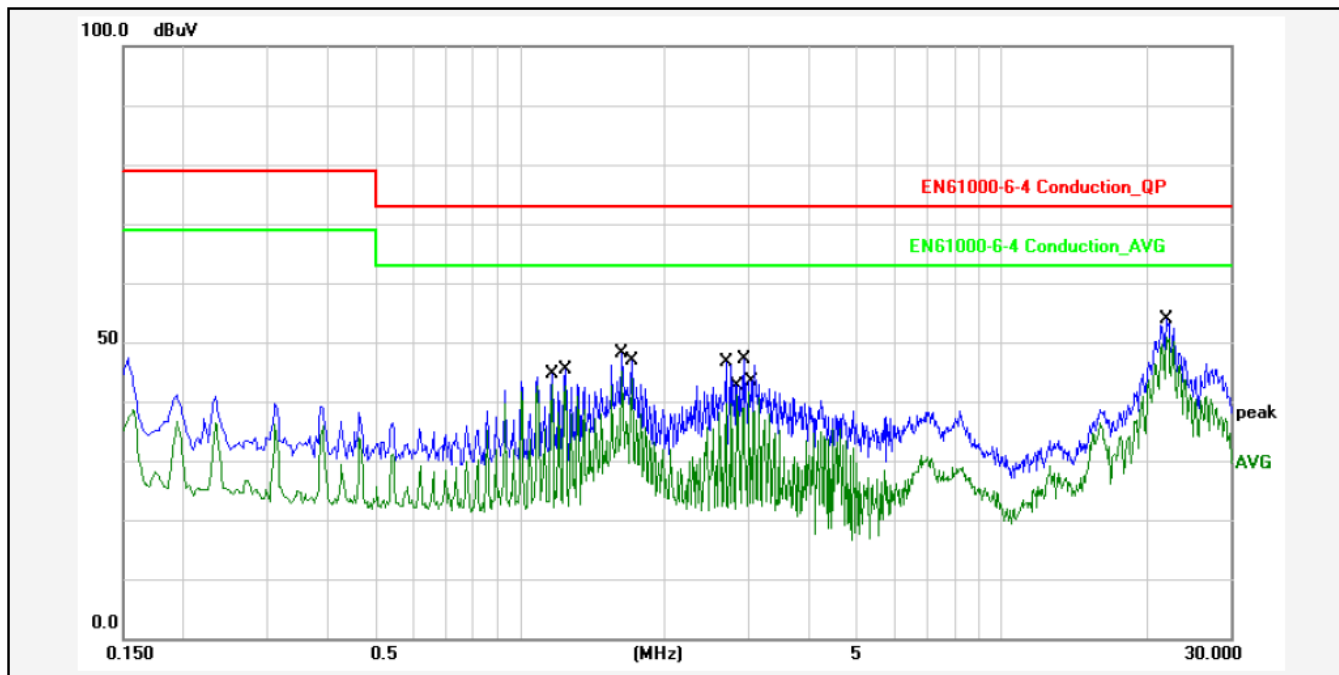

No.	Frequency (MHz)	Factor (dB)	Reading (dBuV)	Level (dBuV)	Limit (dBuV)	Margin (dB)	Detector	P/F	Remark
1	1.1659	10.62	32.20	42.82	63.00	-20.18	AVG	P	
2	1.2459	10.62	34.77	45.39	73.00	-27.61	QP	P	
3	1.6339	10.60	37.62	48.22	73.00	-24.78	QP	P	
4	1.6339	10.60	34.44	45.04	63.00	-17.96	AVG	P	
5	1.7099	10.60	36.20	46.80	73.00	-26.20	QP	P	
6	1.7099	10.60	33.24	43.84	63.00	-19.16	AVG	P	
7	2.6819	10.56	36.19	46.75	73.00	-26.25	QP	P	
8	2.8380	10.56	30.54	41.10	63.00	-21.90	AVG	P	
9	2.9180	10.56	36.56	47.12	73.00	-25.88	QP	P	
10	2.9940	10.56	31.14	41.70	63.00	-21.30	AVG	P	
11	22.1619	10.73	43.21	53.94	73.00	-19.06	QP	P	
12	22.1619	10.73	40.17	50.90	63.00	-12.10	AVG	P	

E.U.T :	FlinInfini Lite On-grid Inverter with Energy storage	Model Name :	FlinInfini Lite 2kW-24V
Temperature :	26 °C	Relative Humidity :	55 %
Pressure :	1006 hPa	Test Voltage :	AC 230V/50Hz
Test Mode :	Normal operation mode	Phase:	Neutral

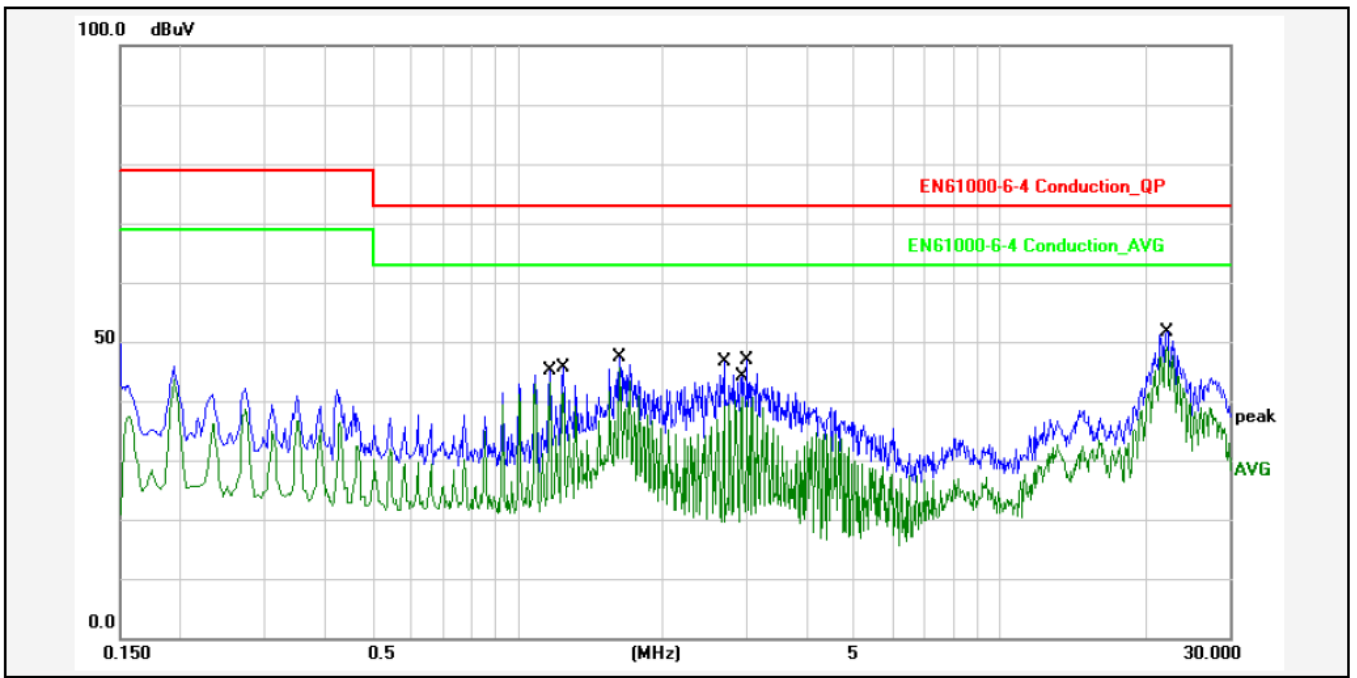

No.	Frequency (MHz)	Factor (dB)	Reading (dBuV)	Level (dBuV)	Limit (dBuV)	Margin (dB)	Detector	P/F	Remark
1	1.1660	10.62	34.47	45.09	73.00	-27.91	QP	P	
2	1.1660	10.62	32.62	43.24	63.00	-19.76	AVG	P	
3	1.2460	10.62	34.93	45.55	73.00	-27.45	QP	P	
4	1.2460	10.62	30.78	41.40	63.00	-21.60	AVG	P	
5	1.6340	10.60	36.80	47.40	73.00	-25.60	QP	P	
6	1.6340	10.60	34.96	45.56	63.00	-17.44	AVG	P	
7	2.6820	10.56	36.00	46.56	73.00	-26.44	QP	P	
8	2.6820	10.56	28.50	39.06	63.00	-23.94	AVG	P	
9	2.9180	10.56	30.04	40.60	63.00	-22.40	AVG	P	
10	2.9940	10.56	36.35	46.91	73.00	-26.09	QP	P	
11	22.2500	10.73	40.94	51.67	73.00	-21.33	QP	P	
12	22.2500	10.73	38.47	49.20	63.00	-13.80	AVG	P	

E.U.T :	FlinInfini Lite On-grid Inverter with Energy storage	Model Name :	FlinInfini Lite 2kW-24V
Temperature :	26 °C	Relative Humidity :	55 %
Pressure :	1006 hPa	Test Voltage :	AC 230V/50Hz PV: 72V
Test Mode :	Normal operation mode+PV	Phase:	Line

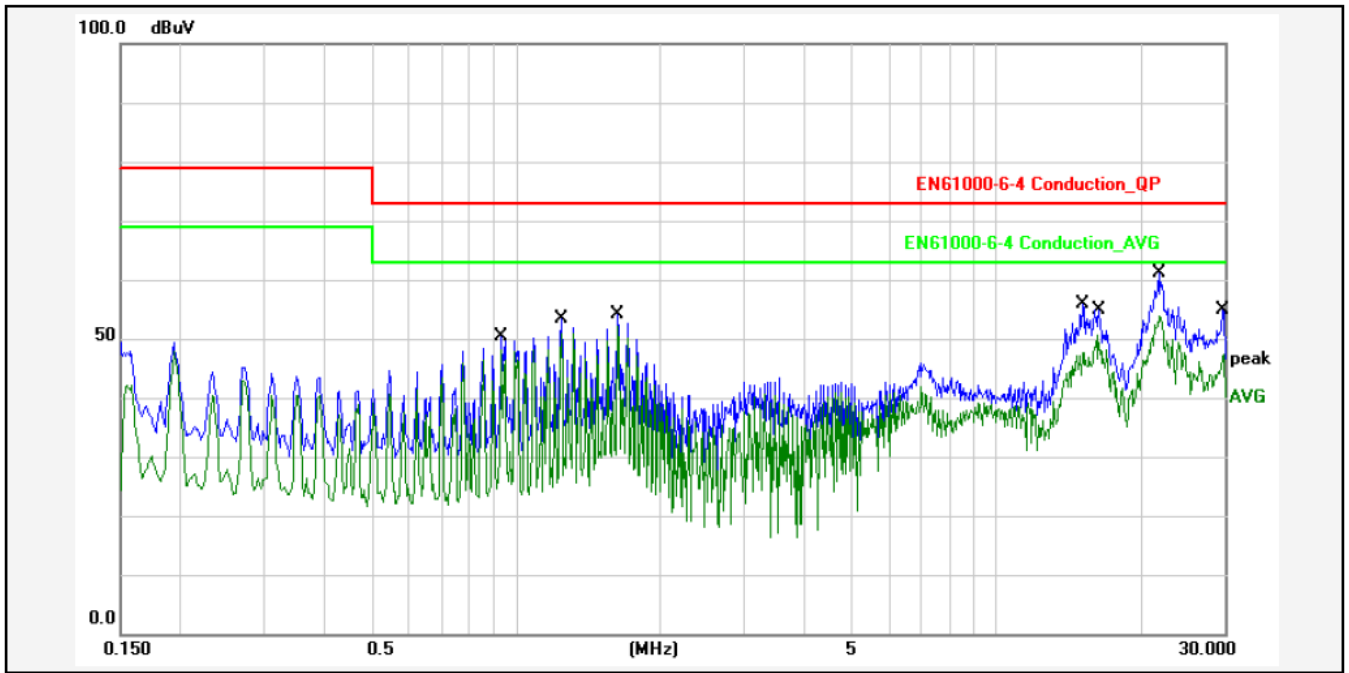

No.	Frequency (MHz)	Factor (dB)	Reading (dBuV)	Level (dBuV)	Limit (dBuV)	Margin (dB)	Detector	P/F	Remark
1	0.9340	10.64	39.78	50.42	73.00	-22.58	QP	P	
2	0.9340	10.64	37.55	48.19	63.00	-14.81	AVG	P	
3	1.2459	10.62	42.74	53.36	73.00	-19.64	QP	P	
4	1.2459	10.62	40.29	50.91	63.00	-12.09	AVG	P	
5	1.6339	10.60	43.64	54.24	73.00	-18.76	QP	P	
6	1.6339	10.60	41.49	52.09	63.00	-10.91	AVG	P	
7	15.2098	10.64	45.19	55.83	73.00	-17.17	QP	P	
8	16.3098	10.66	40.09	50.75	63.00	-12.25	AVG	P	
9	21.8979	10.73	50.40	61.13	73.00	-11.87	QP	P	
10	21.8979	10.73	43.05	53.78	63.00	-9.22	AVG	P	
11	29.7300	10.87	44.06	54.93	73.00	-18.07	QP	P	
12	29.9220	10.87	36.46	47.33	63.00	-15.67	AVG	P	

E.U.T :	FlinInfini Lite On-grid Inverter with Energy storage	Model Name :	FlinInfini Lite 2kW-24V
Temperature :	26 °C	Relative Humidity :	55 %
Pressure :	1006 hPa	Test Voltage :	AC 230V/50Hz PV: 72V
Test Mode :	Normal operation mode+PV	Phase:	Neutral

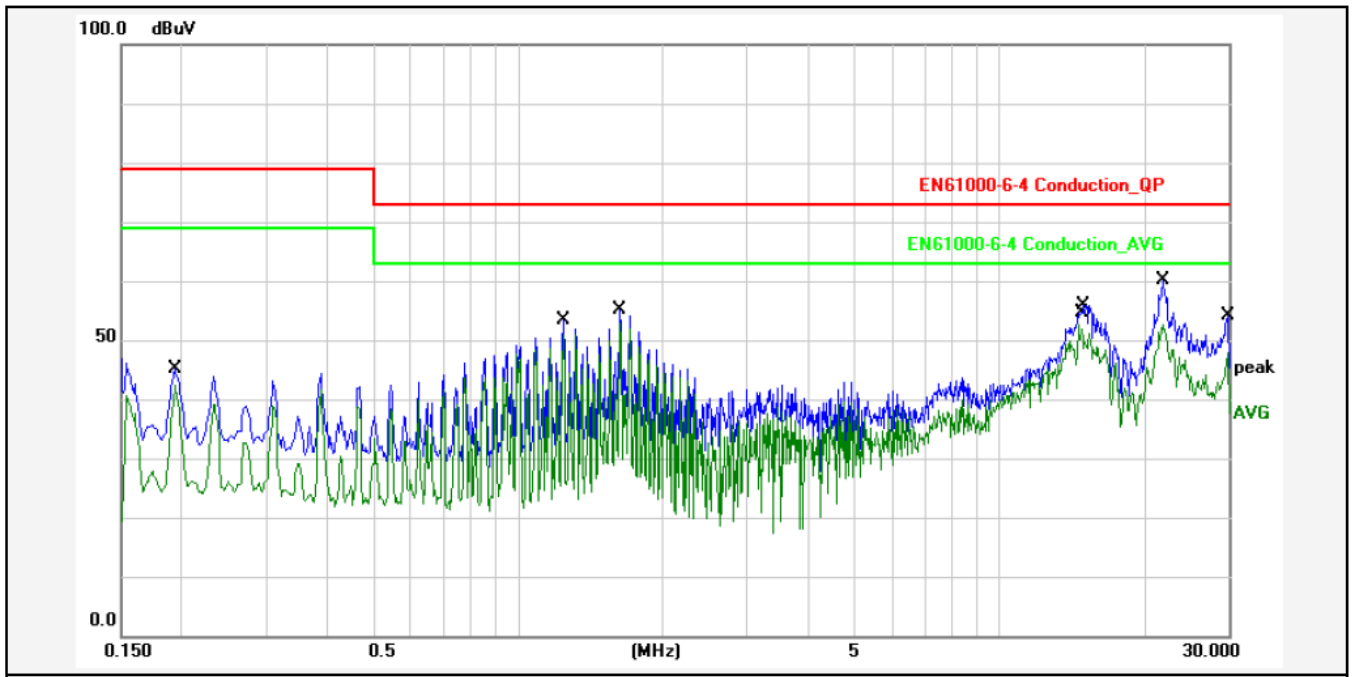

No.	Frequency (MHz)	Factor (dB)	Reading (dBuV)	Level (dBuV)	Limit (dBuV)	Margin (dB)	Detector	P/F	Remark
1	0.1940	10.50	34.73	45.23	79.00	-33.77	QP	P	
2	0.1940	10.50	31.82	42.32	69.00	-26.68	AVG	P	
3	1.2459	10.62	42.65	53.27	73.00	-19.73	QP	P	
4	1.2459	10.62	40.36	50.98	63.00	-12.02	AVG	P	
5	1.6339	10.60	44.60	55.20	73.00	-17.80	QP	P	
6	1.6339	10.60	42.36	52.96	63.00	-10.04	AVG	P	
7	14.6699	10.64	42.01	52.65	63.00	-10.35	AVG	P	
8	15.0579	10.64	45.27	55.91	73.00	-17.09	QP	P	
9	21.8939	10.73	49.29	60.02	73.00	-12.98	QP	P	
10	21.8939	10.73	41.97	52.70	63.00	-10.30	AVG	P	
11	29.9259	10.87	43.17	54.04	73.00	-18.96	QP	P	
12	29.9259	10.87	36.89	47.76	63.00	-15.24	AVG	P	

E.U.T :	FlinInfini Lite On-grid Inverter with Energy storage	Model Name :	FlinInfini Lite 1kW-12V
Temperature :	26 °C	Relative Humidity :	55 %
Pressure :	1006 hPa	Test Voltage :	DC 12V
Test Mode :	Stored Energy operation mode	Phase:	Line

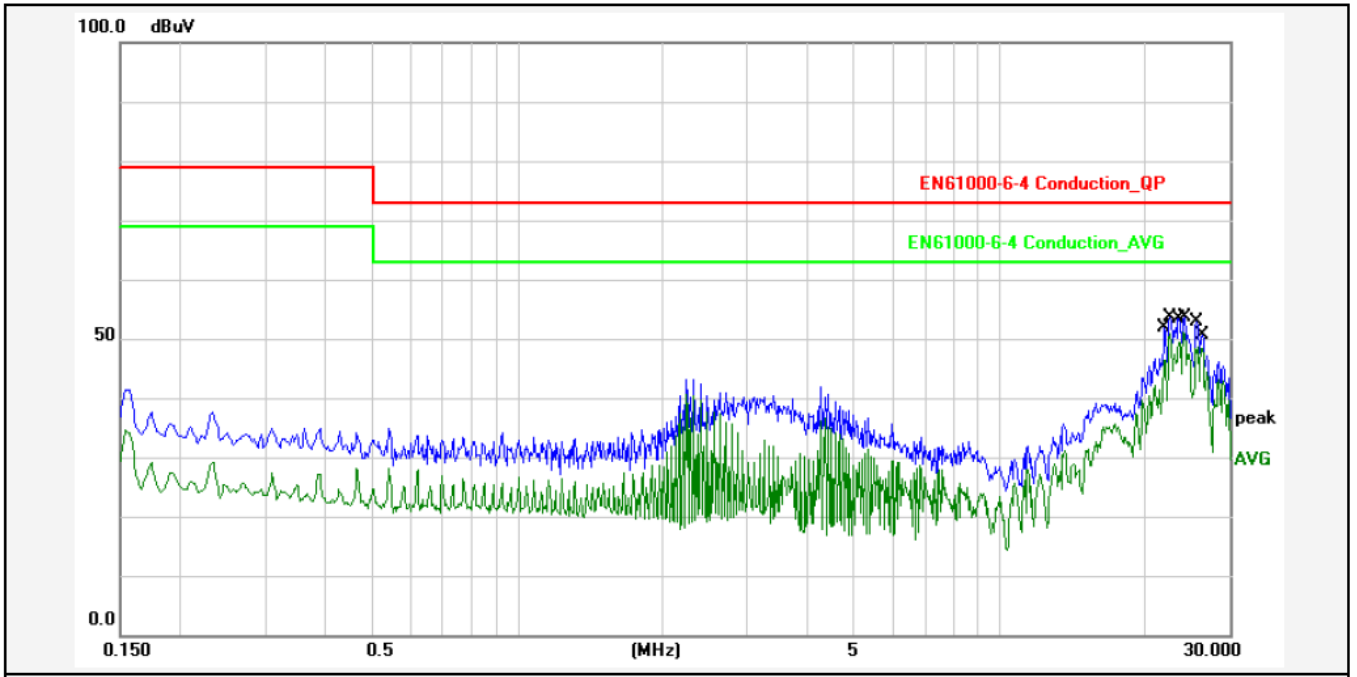

No.	Frequency (MHz)	Factor (dB)	Reading (dBuV)	Level (dBuV)	Limit (dBuV)	Margin (dB)	Detector	P/F	Remark
1	22.0060	10.59	41.35	51.94	73.00	-21.06	QP	P	
2	22.0060	10.59	35.88	46.47	63.00	-16.53	AVG	P	
3	22.5500	10.62	42.93	53.55	73.00	-19.45	QP	P	
4	22.5500	10.62	40.29	50.91	63.00	-12.09	AVG	P	
5	23.6380	10.64	42.23	52.87	73.00	-20.13	QP	P	
6	23.6380	10.64	38.78	49.42	63.00	-13.58	AVG	P	
7	24.1020	10.64	43.01	53.65	73.00	-19.35	QP	P	
8	24.1020	10.64	40.59	51.23	63.00	-11.77	AVG	P	
9	25.7300	10.69	42.16	52.85	73.00	-20.15	QP	P	
10	25.7300	10.69	38.02	48.71	63.00	-14.29	AVG	P	
11	26.3500	10.71	39.99	50.70	73.00	-22.30	QP	P	
12	26.3500	10.71	37.78	48.49	63.00	-14.51	AVG	P	

E.U.T :	FlinInfini Lite On-grid Inverter with Energy storage	Model Name :	FlinInfini Lite 1kW-12V
Temperature :	26 °C	Relative Humidity :	55 %
Pressure :	1006 hPa	Test Voltage :	DC 12V
Test Mode :	Stored Energy operation mode	Phase:	Neutral

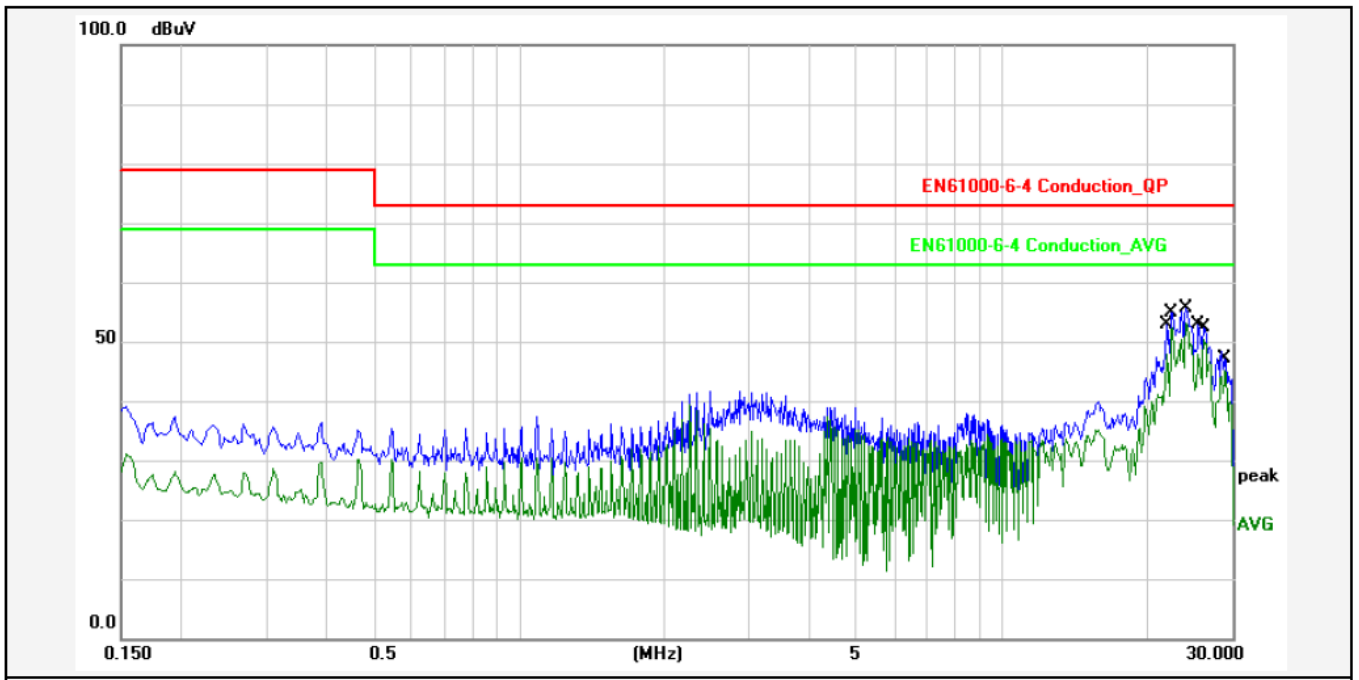

No.	Frequency (MHz)	Factor (dB)	Reading (dBuV)	Level (dBuV)	Limit (dBuV)	Margin (dB)	Detector	P/F	Remark
1	22.0019	10.59	42.38	52.97	73.00	-20.03	QP	P	
2	22.0019	10.59	37.27	47.86	63.00	-15.14	AVG	P	
3	22.6219	10.62	44.30	54.92	73.00	-18.08	QP	P	
4	22.6219	10.62	41.73	52.35	63.00	-10.65	AVG	P	
5	24.0940	10.64	44.87	55.51	73.00	-17.49	QP	P	
6	24.0940	10.64	42.52	53.16	63.00	-9.84	AVG	P	
7	25.5659	10.69	42.15	52.84	73.00	-20.16	QP	P	
8	25.5659	10.69	37.27	47.96	63.00	-15.04	AVG	P	
9	26.2620	10.71	41.70	52.41	73.00	-20.59	QP	P	
10	26.2620	10.71	39.58	50.29	63.00	-12.71	AVG	P	
11	29.0500	10.77	37.56	48.33	73.00	-24.67	QP	P	
12	29.0500	10.77	34.47	45.24	63.00	-17.76	AVG	P	

E.U.T :	FlinInfini Lite On-grid Inverter with Energy storage	Model Name :	FlinInfini Lite 1kW-12V
Temperature :	26 °C	Relative Humidity :	55 %
Pressure :	1006 hPa	Test Voltage :	AC 230V/50Hz
Test Mode :	Normal operation mode	Phase:	Line

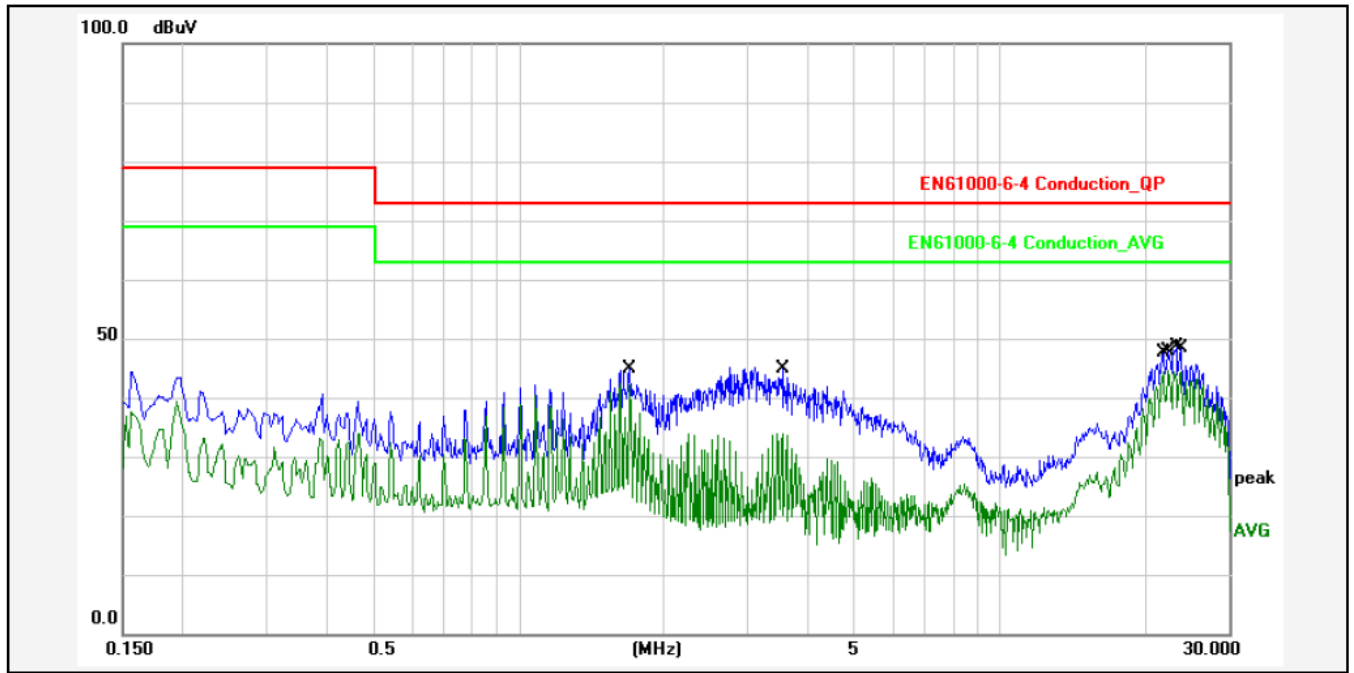

No.	Frequency (MHz)	Factor (dB)	Reading (dBuV)	Level (dBuV)	Limit (dBuV)	Margin (dB)	Detector	P/F	Remark
1	1.7058	10.52	34.32	44.84	73.00	-28.16	QP	P	
2	1.7058	10.52	31.57	42.09	63.00	-20.91	AVG	P	
3	3.5299	10.58	34.54	45.12	73.00	-27.88	QP	P	
4	3.5299	10.58	23.35	33.93	63.00	-29.07	AVG	P	
5	21.7898	10.59	37.08	47.67	73.00	-25.33	QP	P	
6	21.7898	10.59	32.29	42.88	63.00	-20.12	AVG	P	
7	22.4897	10.59	37.29	47.88	73.00	-25.12	QP	P	
8	22.4897	10.59	33.94	44.53	63.00	-18.47	AVG	P	
9	23.1098	10.62	38.02	48.64	73.00	-24.36	QP	P	
10	23.1098	10.62	33.68	44.30	63.00	-18.70	AVG	P	
11	23.8858	10.64	37.85	48.49	73.00	-24.51	QP	P	
12	23.8858	10.64	33.78	44.42	63.00	-18.58	AVG	P	

E.U.T :	FlinInfini Lite On-grid Inverter with Energy storage	Model Name :	FlinInfini Lite 1kW-12V
Temperature :	26 °C	Relative Humidity :	55 %
Pressure :	1006 hPa	Test Voltage :	AC 230V/50Hz
Test Mode :	Normal operation mode	Phase:	Neutral

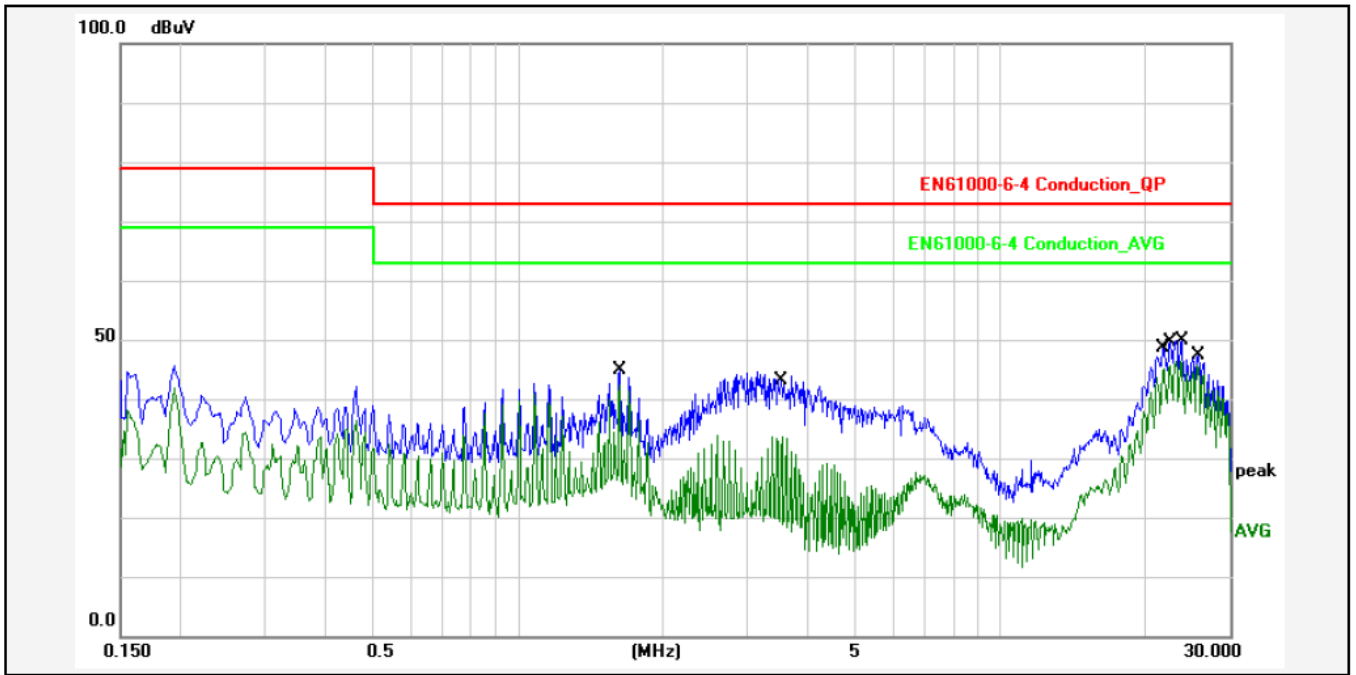

No.	Frequency (MHz)	Factor (dB)	Reading (dBuV)	Level (dBuV)	Limit (dBuV)	Margin (dB)	Detector	P/F	Remark
1	1.6298	10.52	34.24	44.76	73.00	-28.24	QP	P	
2	1.6298	10.52	31.88	42.40	63.00	-20.60	AVG	P	
3	3.5299	10.58	34.07	44.65	73.00	-28.35	QP	P	
4	3.5299	10.58	23.16	33.74	63.00	-29.26	AVG	P	
5	21.8779	10.59	38.04	48.63	73.00	-24.37	QP	P	
6	21.8779	10.59	34.58	45.17	63.00	-17.83	AVG	P	
7	22.5779	10.62	38.98	49.60	73.00	-23.40	QP	P	
8	22.5779	10.62	35.09	45.71	63.00	-17.29	AVG	P	
9	23.7420	10.64	39.31	49.95	73.00	-23.05	QP	P	
10	23.7420	10.64	35.85	46.49	63.00	-16.51	AVG	P	
11	25.6818	10.69	36.65	47.34	73.00	-25.66	QP	P	
12	25.6818	10.69	34.91	45.60	63.00	-17.40	AVG	P	

E.U.T :	FlinInfini Lite On-grid Inverter with Energy storage	Model Name :	FlinInfini Lite 1kW-12V
Temperature :	26 °C	Relative Humidity :	55 %
Pressure :	1006 hPa	Test Voltage :	AC 230V/50Hz PV: 72V
Test Mode :	Normal operation mode+PV	Phase:	Line

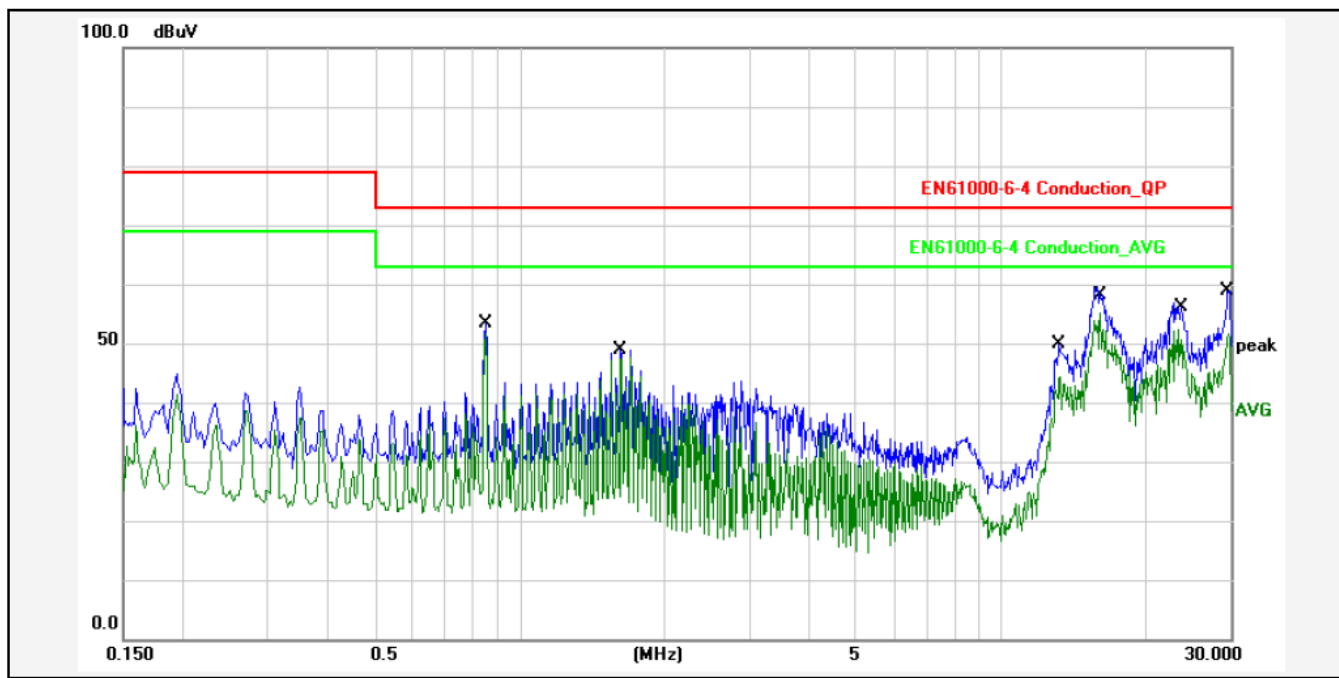

No.	Frequency (MHz)	Factor (dB)	Reading (dBuV)	Level (dBuV)	Limit (dBuV)	Margin (dB)	Detector	P/F	Remark
1	0.8500	10.46	43.05	53.51	73.00	-19.49	QP	P	
2	0.8500	10.46	41.12	51.58	63.00	-11.42	AVG	P	
3	1.6260	10.52	38.49	49.01	73.00	-23.99	QP	P	
4	1.6260	10.52	36.89	47.41	63.00	-15.59	AVG	P	
5	13.2699	10.49	39.33	49.82	73.00	-23.18	QP	P	
6	13.2699	10.49	33.96	44.45	63.00	-18.55	AVG	P	
7	16.0619	10.50	49.04	59.54	73.00	-13.46	QP	P	
8	16.0619	10.50	44.59	55.09	63.00	-7.91	AVG	P	
9	23.4460	10.62	46.30	56.92	73.00	-16.08	QP	P	
10	23.4460	10.62	41.73	52.35	63.00	-10.65	AVG	P	
11	29.6300	10.79	48.19	58.98	73.00	-14.02	QP	P	
12	29.6300	10.79	39.78	50.57	63.00	-12.43	AVG	P	

E.U.T :	FlinInfini Lite On-grid Inverter with Energy storage	Model Name :	FlinInfini Lite 1kW-12V
Temperature :	26 °C	Relative Humidity :	55 %
Pressure :	1006 hPa	Test Voltage :	AC 230V/50Hz PV: 72V
Test Mode :	Normal operation mode+PV	Phase:	Neutral

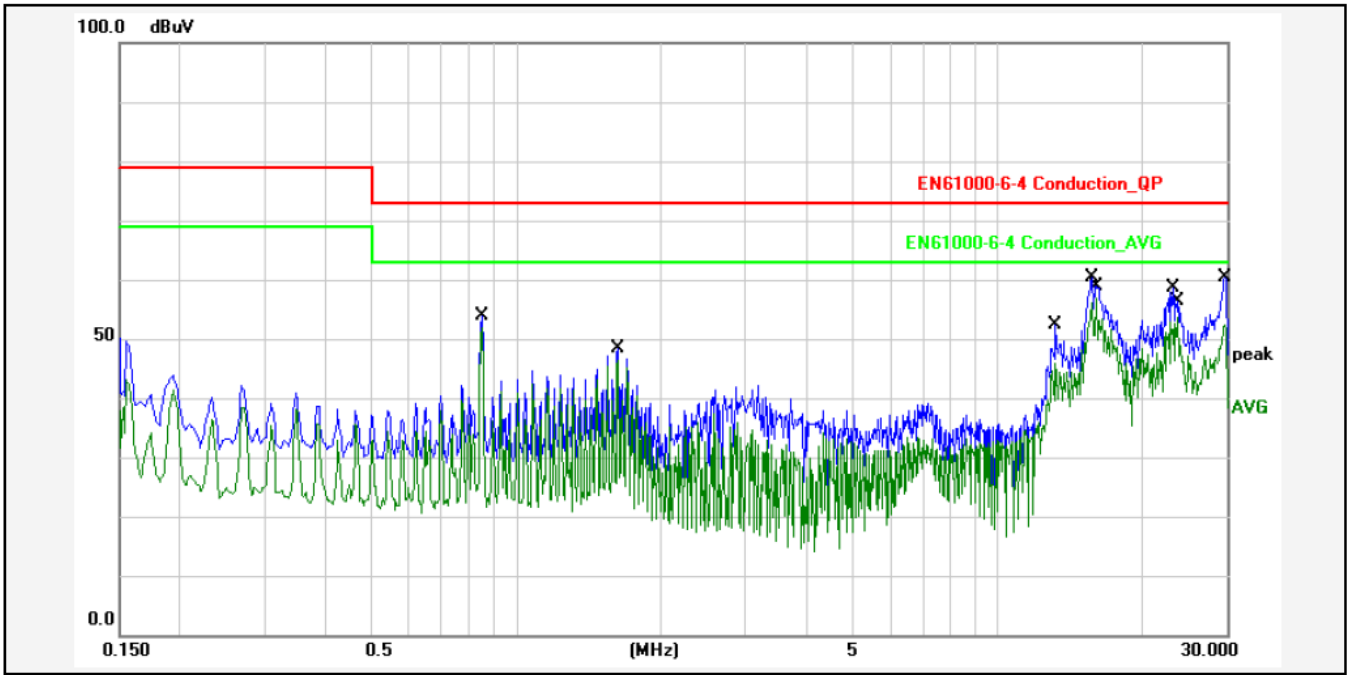

No.	Frequency (MHz)	Factor (dB)	Reading (dBuV)	Level (dBuV)	Limit (dBuV)	Margin (dB)	Detector	P/F	Remark
1	0.8500	10.46	43.48	53.94	73.00	-19.06	QP	P	
2	0.8500	10.46	41.51	51.97	63.00	-11.03	AVG	P	
3	1.6300	10.52	37.83	48.35	73.00	-24.65	QP	P	
4	1.6300	10.52	35.95	46.47	63.00	-16.53	AVG	P	
5	13.2659	10.49	41.79	52.28	73.00	-20.72	QP	P	
6	13.2659	10.49	35.46	45.95	63.00	-17.05	AVG	P	
7	15.7579	10.50	49.86	60.36	73.00	-12.64	QP	P	
8	16.0579	10.50	43.70	54.20	63.00	-8.80	AVG	P	
9	23.2460	10.62	47.92	58.54	73.00	-14.46	QP	P	
10	23.7420	10.64	43.02	53.66	63.00	-9.34	AVG	P	
11	29.7260	10.79	49.69	60.48	73.00	-12.52	QP	P	
12	29.7260	10.79	41.50	52.29	63.00	-10.71	AVG	P	

5. RADIATED EMISSION MEASUREMENT

5.1 Block Diagram of Test

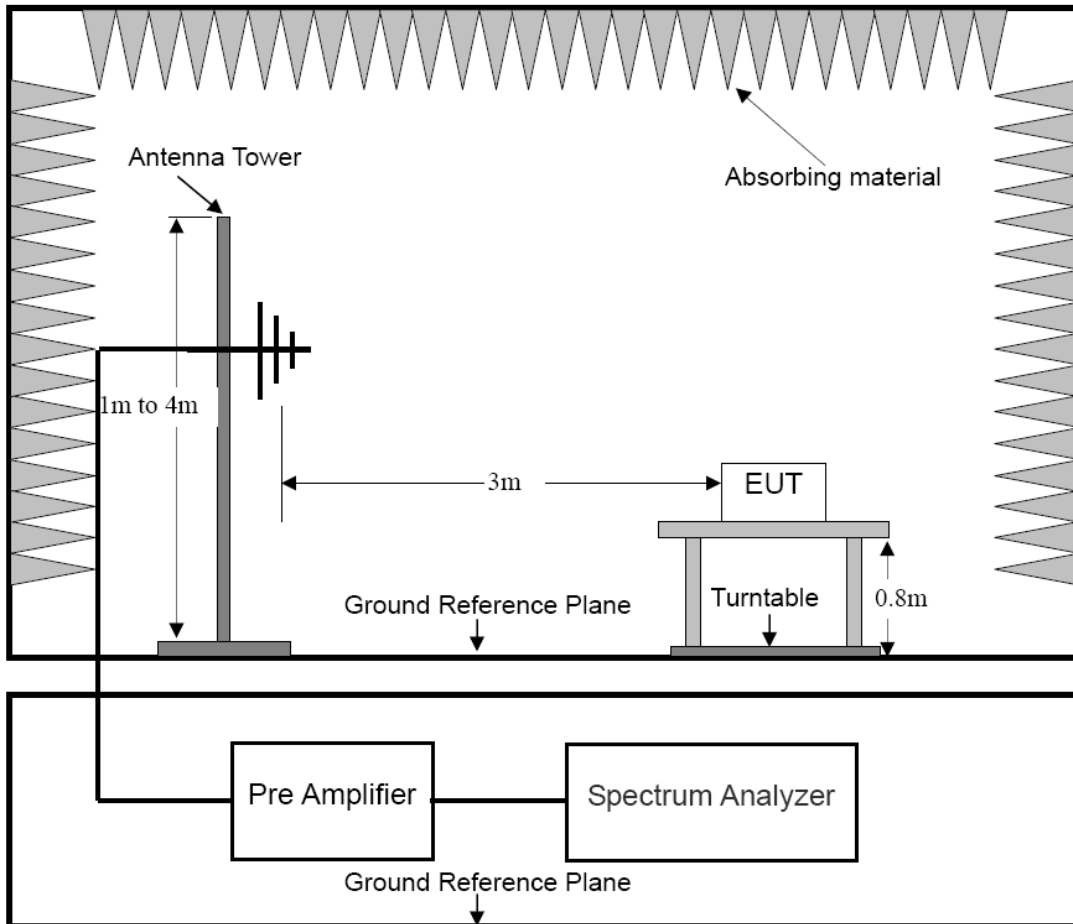

5.2 Limit of Radiated Emission Measurement

Test Standard: EN 61000-6-4

Limits for radiated disturbance at a measuring distance of 3m

Frequency range MHz	Quasi-peak limits dB(uV/m)
30 to 230	50
230 to 1000	57

Note 1 The lower limit shall apply at the transition frequency.
 Note 2 If the internal emission source is operating at a frequency below 9KHz, then measurements need only to be performed up to 230MHz

5.3 Test Procedure

E.U.T. and its simulators are placed on a turntable, which is 0.8 meter high above ground. The turntable can rotate 360 degrees to determine the position of the maximum emission level. E.U.T. is set 3.0 meters away from the receiving antenna, which is mounted on a antenna tower. The antenna can be moved up and down between 1.0 meter and 4 meters to find out the maximum emission level. Broadband antenna (calibrated bilog antenna) is used as receiving antenna. Both horizontal and vertical polarization of the antenna is set on measurement. In order to find the maximum emission levels, all of the interface cables must be manipulated according to EN 61000-6-4 on radiated emission measurement.

The bandwidth of the EMI test receiver (R&S ESCI7) is set at 120 KHz. The frequency range from 30 MHz to 1000 MHz is checked.

5.4 Operating Condition of E.U.T.

5.4.1 Setup the E.U.T. and simulators as shown in Section 2.3.

5.4.2 Turn on the power of all equipments.

5.4.3 Let the E.U.T. work in test mode and test it.

5.5 Radiated Emission Measurement Result

PASS.

Please refer to the following pages.

E.U.T :	FlinInfini Lite On-grid Inverter with Energy storage	Model Name :	FlinInfini Lite 2kW-24V
Temperature :	25 °C	Relative Humidity :	60 %
Pressure :	1006 hPa	Test Voltage :	DC 24V
Test Mode :	Stored Energy operation mode	Polarization:	Vertical



No.	Frequency (MHz)	Factor (dB/m)	Reading (dBuV)	Level (dBuV/m)	Limit (dBuV/m)	Margin (dB)	Detector	Height (cm)	Azimuth (deg.)	P/F	Remark
1	30.4084	-0.81	45.72	44.91	50.00	-5.09	QP			P	
2	34.2760	-1.92	47.17	45.25	50.00	-4.75	QP			P	
3	43.8119	-6.46	53.16	46.70	50.00	-3.30	QP			P	
4	57.5939	-13.05	53.33	40.28	50.00	-9.72	QP			P	
5	68.3908	-12.30	49.16	36.86	50.00	-13.14	QP			P	
6	97.7983	-6.74	45.50	38.76	50.00	-11.24	QP			P	

E.U.T :	FlinInfini Lite On-grid Inverter with Energy storage	Model Name :	FlinInfini Lite 2kW-24V
Temperature :	25 °C	Relative Humidity :	60 %
Pressure :	1006 hPa	Test Voltage :	DC 24V
Test Mode :	Stored Energy operation mode	Polarization:	Horizontal

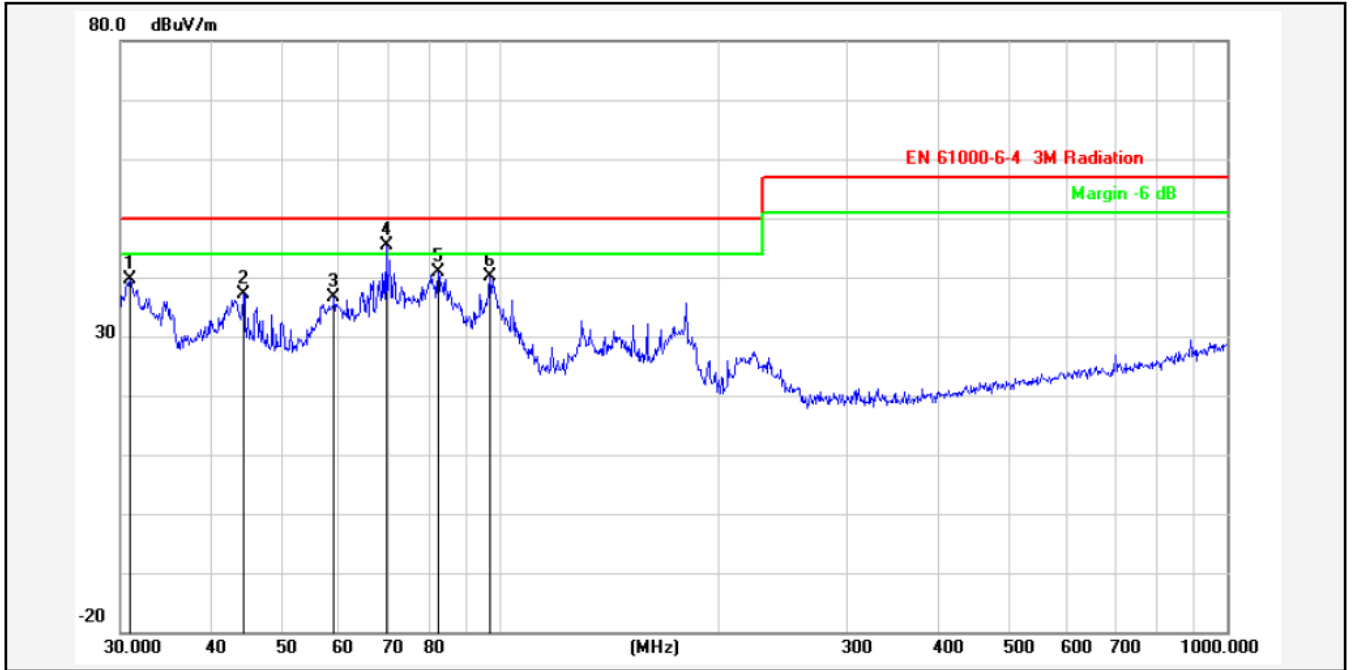

No.	Frequency (MHz)	Factor (dB/m)	Reading (dBuV)	Level (dBuV/m)	Limit (dBuV/m)	Margin (dB)	Detector	Height (cm)	Azimuth (deg.)	P/F	Remark
1	30.8535	-0.94	40.47	39.53	50.00	-10.47	QP			P	
2	44.2752	-6.82	44.02	37.20	50.00	-12.80	QP			P	
3	59.0251	-13.39	50.14	36.75	50.00	-13.25	QP			P	
4	69.6005	-12.12	57.56	45.44	50.00	-4.56	QP			P	
5	82.0706	-9.56	50.32	40.76	50.00	-9.24	QP			P	
6	96.7749	-6.89	46.97	40.08	50.00	-9.92	QP			P	

E.U.T :	FlinInfini Lite On-grid Inverter with Energy storage	Model Name :	FlinInfini Lite 2kW-24V
Temperature :	25 °C	Relative Humidity :	60 %
Pressure :	1006 hPa	Test Voltage :	AC230V/50Hz
Test Mode :	Normal operation mode	Polarization:	Horizontal

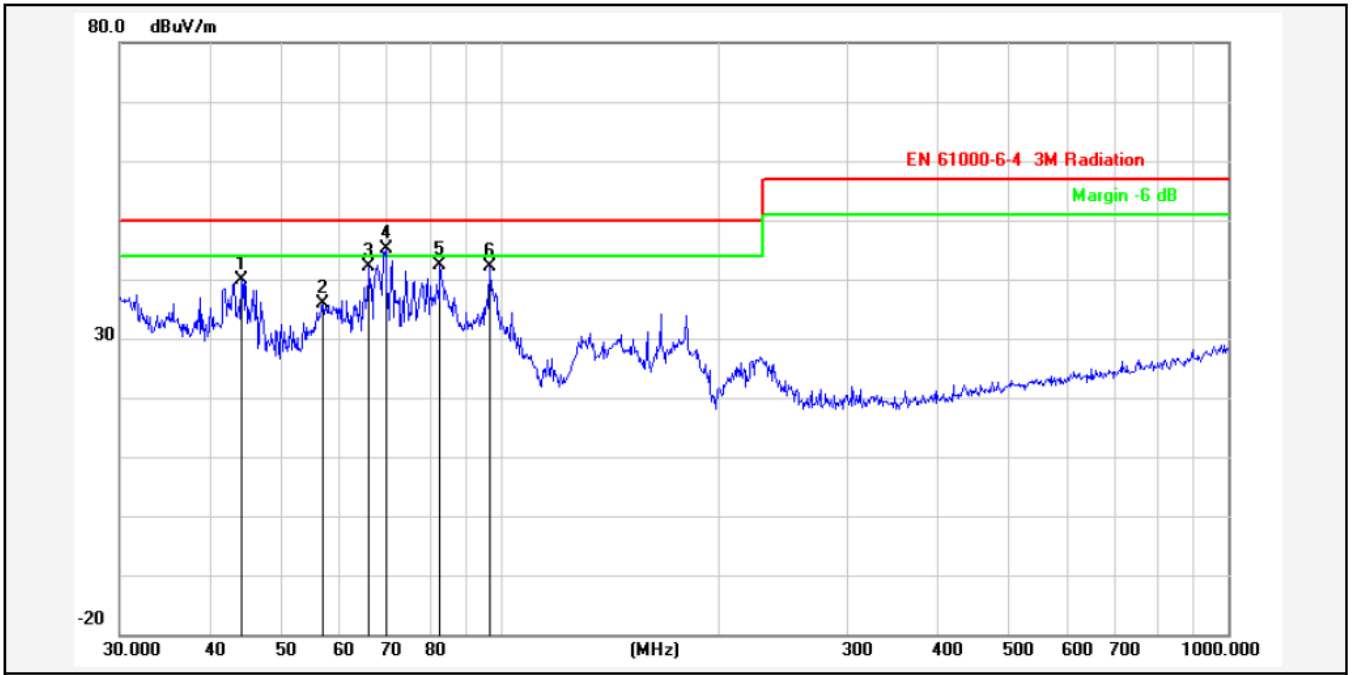

No.	Frequency (MHz)	Factor (dB/m)	Reading (dBuV)	Level (dBuV/m)	Limit (dBuV/m)	Margin (dB)	Detector	Height (cm)	Azimuth (deg.)	P/F	Remark
1	44.1202	-6.71	46.57	39.86	50.00	-10.14	QP			P	
2	56.9912	-12.90	48.79	35.89	50.00	-14.11	QP			P	
3	66.0342	-12.68	54.90	42.22	50.00	-7.78	QP			P	
4	69.6005	-12.12	57.28	45.16	50.00	-4.84	QP			P	
5	82.6482	-9.44	51.87	42.43	50.00	-7.57	QP			P	
6	96.7749	-6.89	49.01	42.12	50.00	-7.88	QP			P	

E.U.T :	FlinInfini Lite On-grid Inverter with Energy storage	Model Name :	FlinInfini Lite 2kW-24V
Temperature :	25 °C	Relative Humidity :	60 %
Pressure :	1006 hPa	Test Voltage :	AC230V/50Hz
Test Mode :	Normal operation mode	Polarization:	Vertical

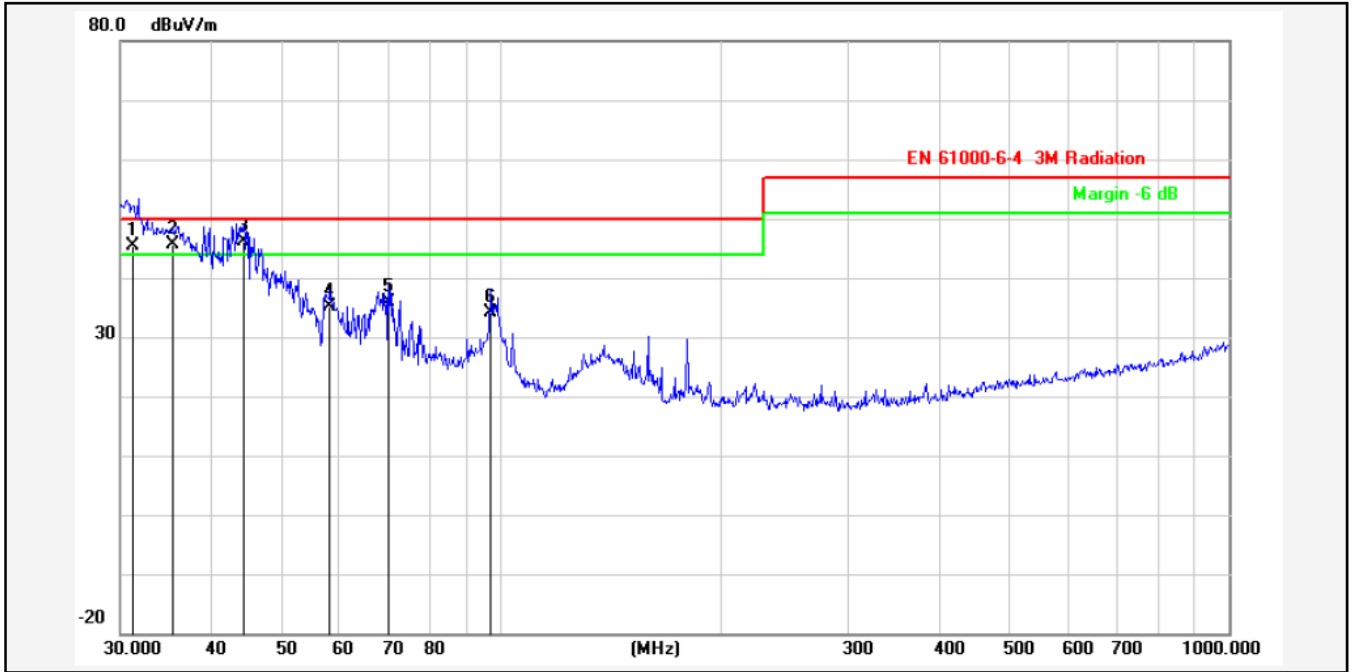

No.	Frequency (MHz)	Factor (dB/m)	Reading (dBuV)	Level (dBuV/m)	Limit (dBuV/m)	Margin (dB)	Detector	Height (cm)	Azimuth (deg.)	P/F	Remark
1	31.1990	-1.04	46.38	45.34	50.00	-4.66	QP			P	
2	35.3750	-2.23	47.94	45.71	50.00	-4.29	QP			P	
3	44.2752	-6.82	52.96	46.14	50.00	-3.86	QP			P	
4	58.2029	-13.19	48.36	35.17	50.00	-14.83	QP			P	
5	70.0902	-12.03	47.95	35.92	50.00	-14.08	QP			P	
6	96.7749	-6.89	41.14	34.25	50.00	-15.75	QP			P	

E.U.T :	FlinInfini Lite On-grid Inverter with Energy storage	Model Name :	FlinInfini Lite 2kW-24V
Temperature :	25 °C	Relative Humidity :	60 %
Pressure :	1006 hPa	Test Voltage :	AC230V/50Hz DC 72V
Test Mode :	Normal operation mode+PV	Polarization:	Vertical

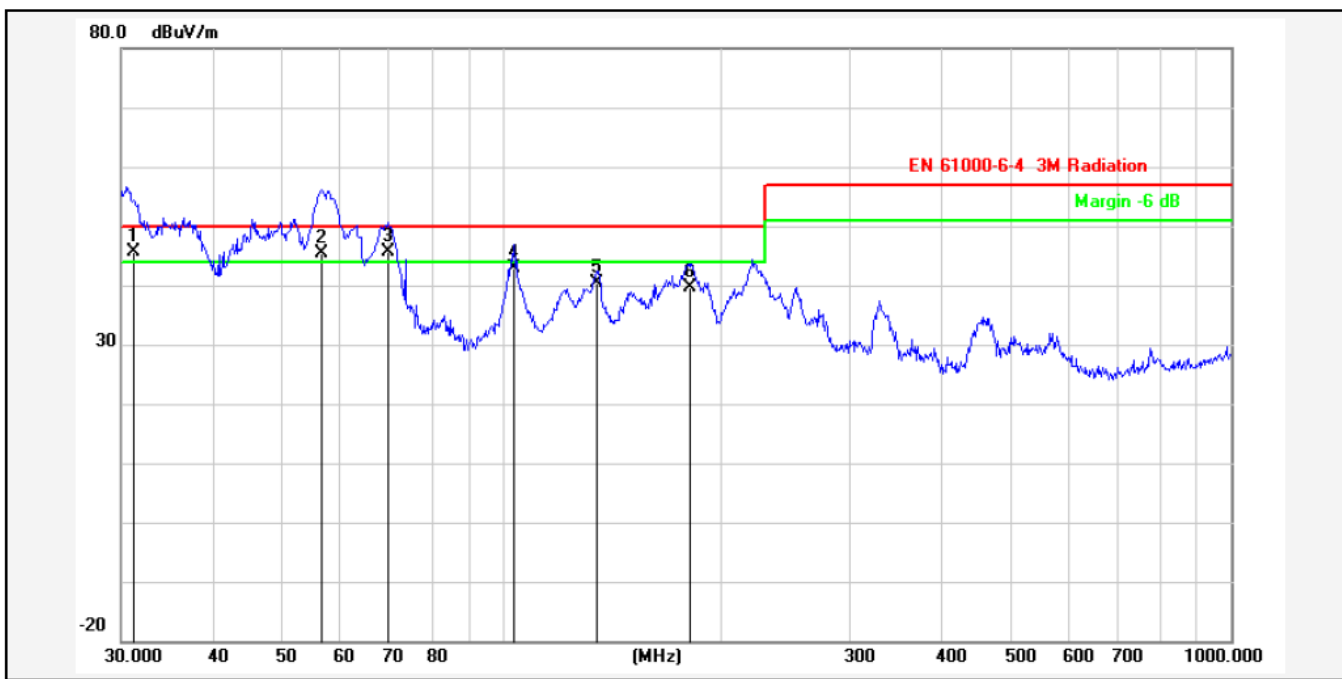

No.	Frequency (MHz)	Factor (dB/m)	Reading (dBuV)	Level (dBuV/m)	Limit (dBuV/m)	Margin (dB)	Detector	Height (cm)	Azimuth (deg.)	P/F	Remark
1	31.0992	-1.01	46.54	45.53	50.00	-4.47	QP			P	
2	56.4339	-12.76	58.06	45.30	50.00	-4.70	QP			P	
3	69.6003	-12.12	57.65	45.53	50.00	-4.47	QP			P	
4	103.8054	-6.26	49.22	42.96	50.00	-7.04	QP			P	
5	134.5591	-5.57	46.03	40.46	50.00	-9.54	QP			P	
6	181.2834	-7.60	47.26	39.66	50.00	-10.34	QP			P	

E.U.T :	FlinInfini Lite On-grid Inverter with Energy storage	Model Name :	FlinInfini Lite 2kW-24V
Temperature :	25 °C	Relative Humidity :	60 %
Pressure :	1006 hPa	Test Voltage :	AC230V/50Hz DC 72V
Test Mode :	Normal operation mode+PV	Polarization:	Horizontal



No.	Frequency (MHz)	Factor (dB/m)	Reading (dBuV)	Level (dBuV/m)	Limit (dBuV/m)	Margin (dB)	Detector	Height (cm)	Azimuth (deg.)	P/F	Remark
1	43.5056	-6.23	50.87	44.64	50.00	-5.36	QP			P	
2	56.2441	-12.72	58.12	45.40	50.00	-4.60	QP			P	
3	68.1512	-12.35	54.15	41.80	50.00	-8.20	QP			P	
4	102.3596	-6.31	45.11	38.80	50.00	-11.20	QP			P	
5	139.0146	-5.80	40.90	35.10	50.00	-14.90	QP			P	
6	188.4122	-7.83	48.37	40.54	50.00	-9.46	QP			P	

E.U.T :	FlinInfini Lite On-grid Inverter with Energy storage	Model Name :	FlinInfini Lite 1kW-12V
Temperature :	25 °C	Relative Humidity :	60 %
Pressure :	1006 hPa	Test Voltage :	DC 12V
Test Mode :	Stored Energy operation mode	Polarization:	Vertical



No.	Frequency (MHz)	Factor (dB/m)	Reading (dBuV)	Level (dBuV/m)	Limit (dBuV/m)	Margin (dB)	Detector	Height (cm)	Azimuth (deg.)	P/F	Remark
1	33.0950	-1.58	45.16	43.58	50.00	-6.42	QP			P	
2	39.2991	-3.35	47.89	44.54	50.00	-5.46	QP			P	
3	41.4900	-4.69	48.35	43.66	50.00	-6.34	QP			P	
4	73.3593	-11.36	48.18	36.82	50.00	-13.18	QP			P	
5	143.8293	-6.04	40.27	34.23	50.00	-15.77	QP			P	
6	214.5141	-7.01	42.09	35.08	50.00	-14.92	QP			P	

E.U.T :	FlinInfini Lite On-grid Inverter with Energy storage	Model Name :	FlinInfini Lite 1kW-12V
Temperature :	25 °C	Relative Humidity :	60 %
Pressure :	1006 hPa	Test Voltage :	DC 12V
Test Mode :	Stored Energy operation mode	Polarization:	Horizontal

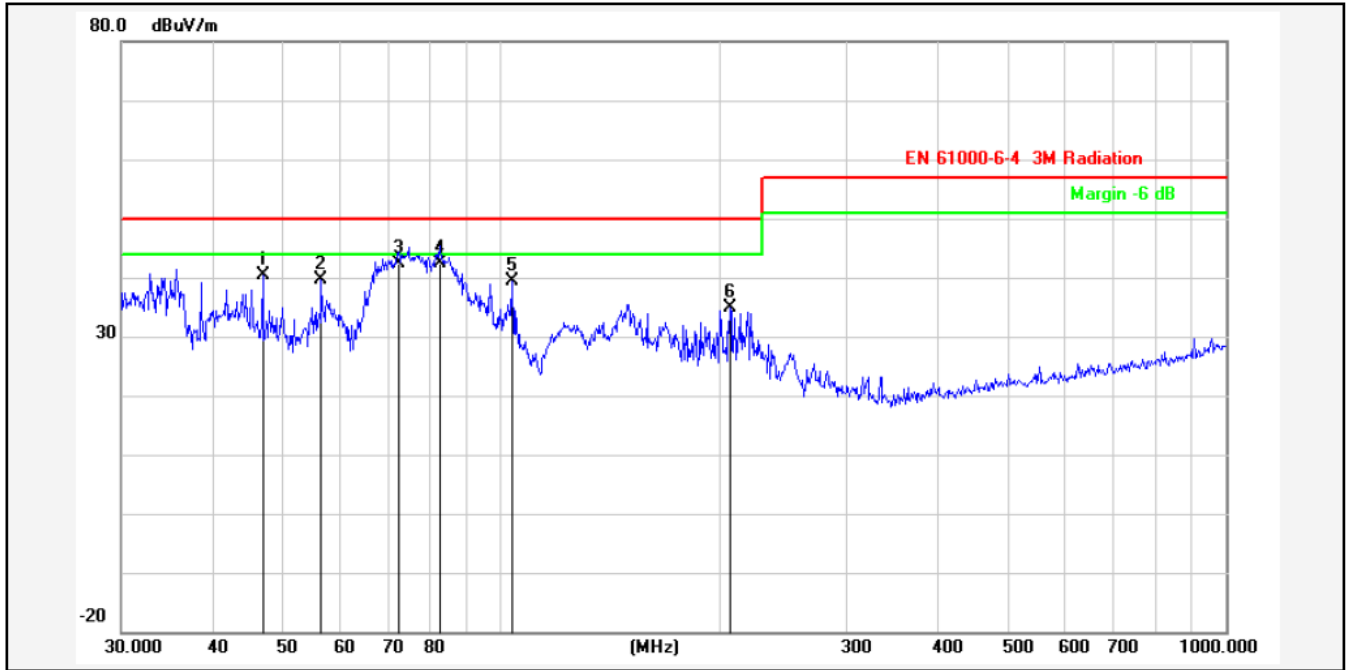

No.	Frequency (MHz)	Factor (dB/m)	Reading (dBuV)	Level (dBuV/m)	Limit (dBuV/m)	Margin (dB)	Detector	Height (cm)	Azimuth (deg.)	P/F	Remark
1	46.9948	-8.91	49.18	40.27	50.00	-9.73	QP			P	
2	56.5929	-12.80	52.40	39.60	50.00	-10.40	QP			P	
3	72.3376	-11.56	54.00	42.44	50.00	-7.56	QP			P	
4	82.3588	-9.50	51.93	42.43	50.00	-7.57	QP			P	
5	103.8055	-6.26	45.71	39.45	50.00	-10.55	QP			P	
6	207.1226	-7.62	42.60	34.98	50.00	-15.02	QP			P	

E.U.T :	FlinInfini Lite On-grid Inverter with Energy storage	Model Name :	FlinInfini Lite 1kW-12V
Temperature :	25 °C	Relative Humidity :	60 %
Pressure :	1006 hPa	Test Voltage :	AC230V/50Hz
Test Mode :	Normal operation mode	Polarization:	Horizontal



No.	Frequency (MHz)	Factor (dB/m)	Reading (dBuV)	Level (dBuV/m)	Limit (dBuV/m)	Margin (dB)	Detector	Height (cm)	Azimuth (deg.)	P/F	Remark
1	33.7986	-1.78	42.21	40.43	50.00	-9.57	QP			P	
2	37.0248	-2.70	41.15	38.45	50.00	-11.55	QP			P	
3	57.5939	-13.05	50.32	37.27	50.00	-12.73	QP			P	
4	73.3593	-11.36	55.12	43.76	50.00	-6.24	QP			P	
5	96.7749	-6.89	47.06	40.17	50.00	-9.83	QP			P	
6	159.2250	-6.72	40.97	34.25	50.00	-15.75	QP			P	

E.U.T :	FlinInfini Lite On-grid Inverter with Energy storage	Model Name :	FlinInfini Lite 1kW-12V
Temperature :	25 °C	Relative Humidity :	60 %
Pressure :	1006 hPa	Test Voltage :	AC230V/50Hz
Test Mode :	Normal operation mode	Polarization:	Vertical

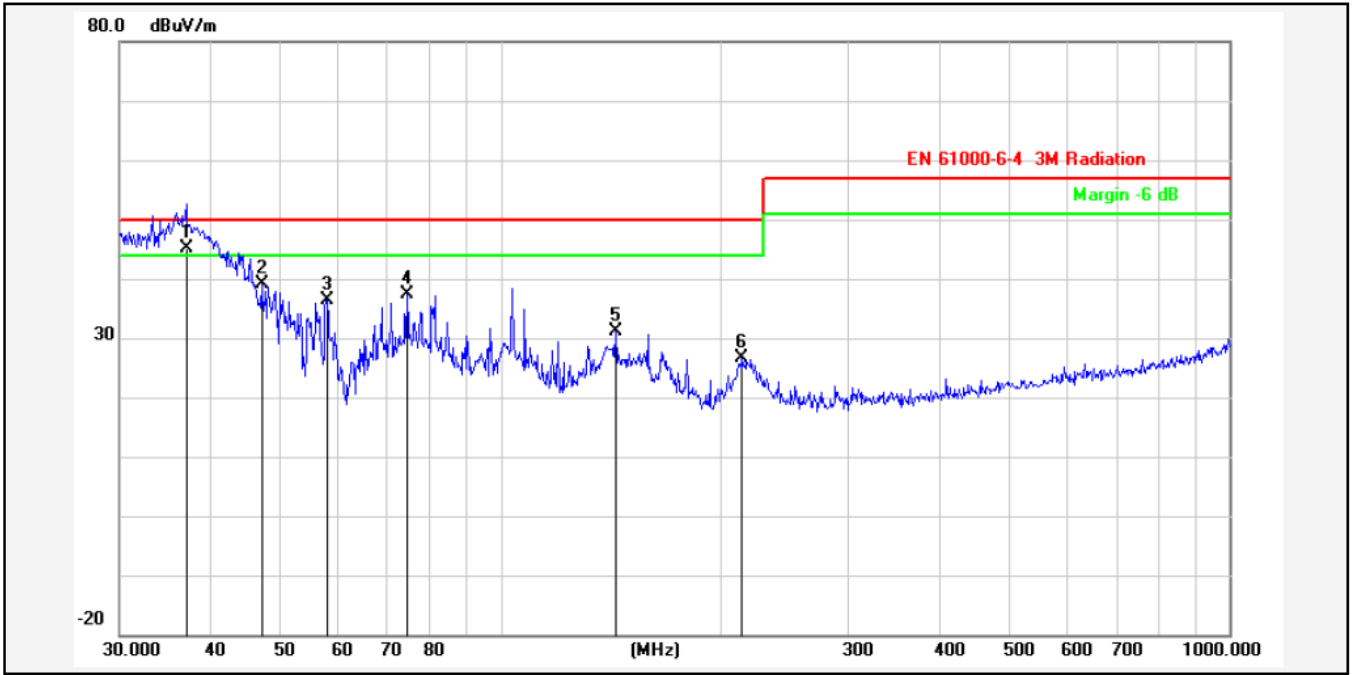

No.	Frequency (MHz)	Factor (dB/m)	Reading (dBuV)	Level (dBuV/m)	Limit (dBuV/m)	Margin (dB)	Detector	Height (cm)	Azimuth (deg.)	P/F	Remark
1	37.0248	-2.70	47.91	45.21	50.00	-4.79	QP			P	
2	46.9948	-8.91	48.10	39.19	50.00	-10.81	QP			P	
3	57.7961	-13.10	49.48	36.38	50.00	-13.62	QP			P	
4	74.3955	-11.14	48.59	37.45	50.00	-12.55	QP			P	
5	143.8294	-6.04	37.15	31.11	50.00	-18.89	QP			P	
6	214.5141	-7.01	33.74	26.73	50.00	-23.27	QP			P	

E.U.T :	FlinInfini Lite On-grid Inverter with Energy storage	Model Name :	FlinInfini Lite 1kW-12V
Temperature :	25 °C	Relative Humidity :	60 %
Pressure :	1006 hPa	Test Voltage :	AC230V/50Hz DC 72V
Test Mode :	Normal operation mode+PV	Polarization:	Vertical

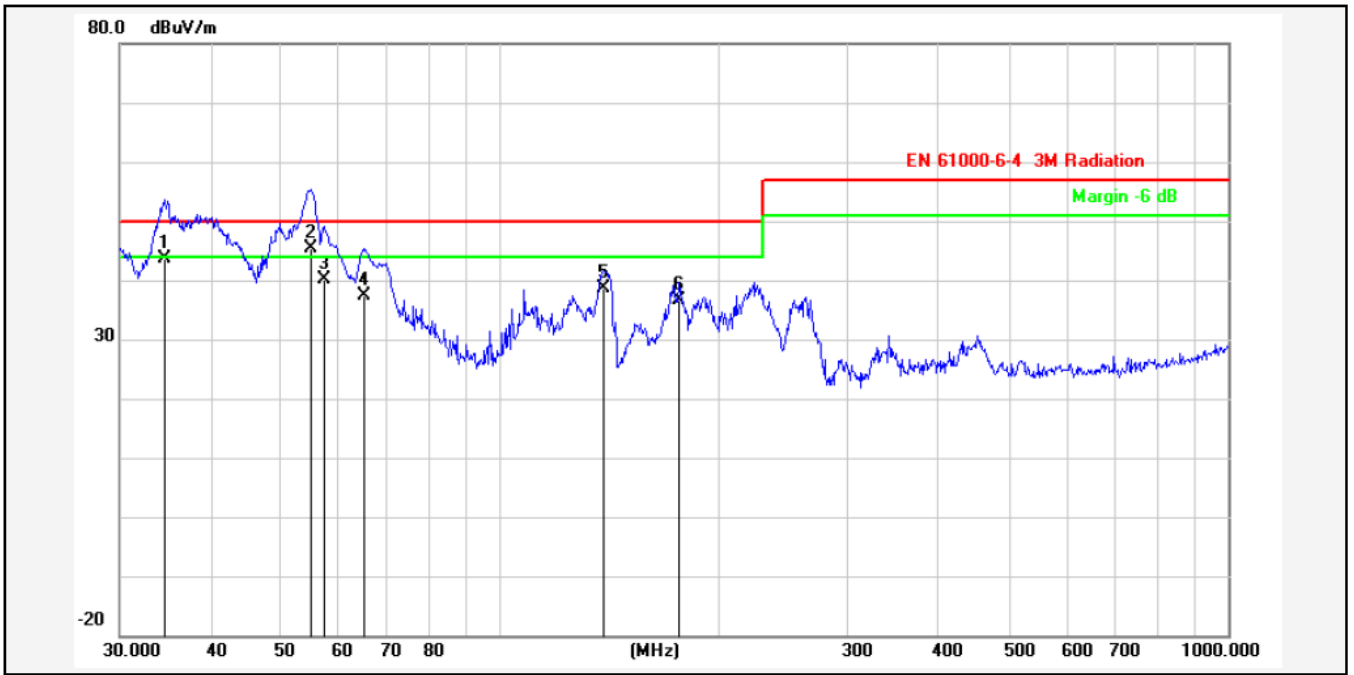

No.	Frequency (MHz)	Factor (dB/m)	Reading (dBuV)	Level (dBuV/m)	Limit (dBuV/m)	Margin (dB)	Detector	Height (cm)	Azimuth (deg.)	P/F	Remark
1	34.6385	-2.02	45.58	43.56	50.00	-6.44	QP			P	
2	54.8348	-12.38	57.88	45.50	50.00	-4.50	QP			P	
3	57.1914	-12.94	53.13	40.19	50.00	-9.81	QP			P	
4	64.8863	-12.86	50.32	37.46	50.00	-12.54	QP			P	
5	138.3873	-5.77	44.52	38.75	50.00	-11.25	QP			P	
6	176.2684	-7.41	44.04	36.63	50.00	-13.37	QP			P	

E.U.T :	FlinInfini Lite On-grid Inverter with Energy storage	Model Name :	FlinInfini Lite 1kW-12V
Temperature :	25 °C	Relative Humidity :	60 %
Pressure :	1006 hPa	Test Voltage :	AC230V/50Hz DC 72V
Test Mode :	Normal operation mode+PV	Polarization:	Horizontal

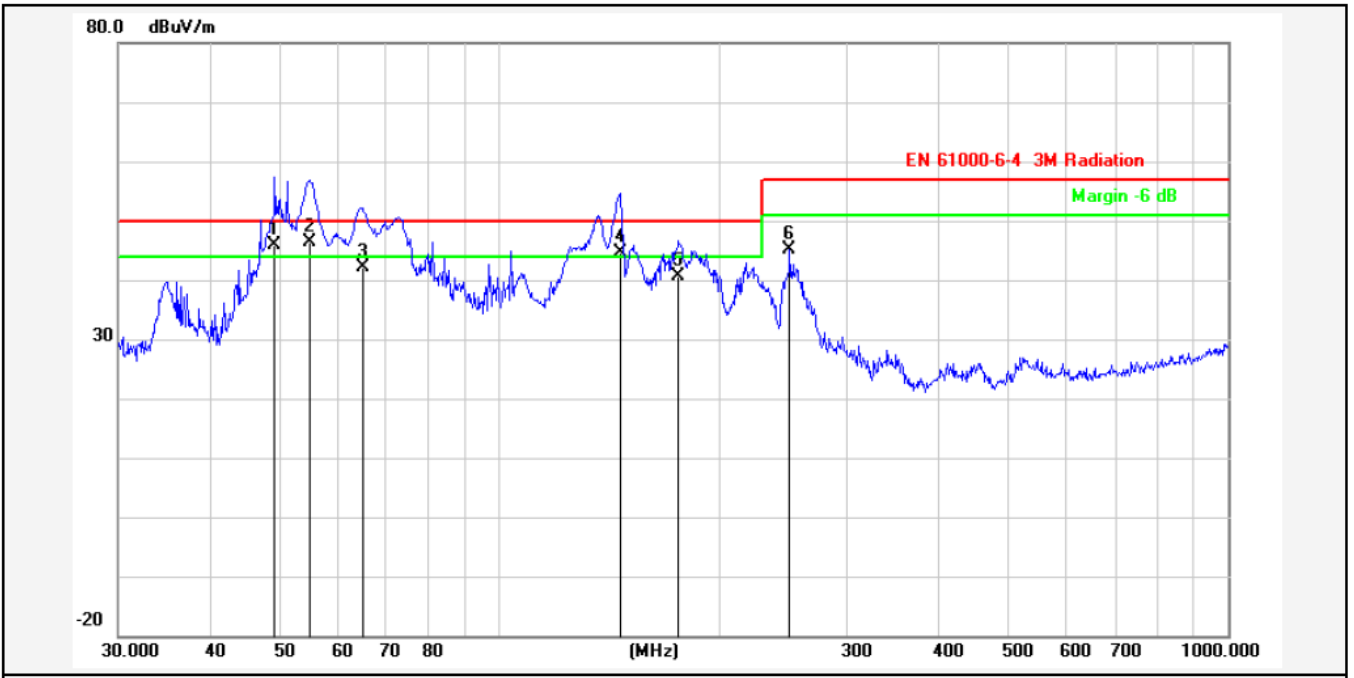

No.	Frequency (MHz)	Factor (dB/m)	Reading (dBuV)	Level (dBuV/m)	Limit (dBuV/m)	Margin (dB)	Detector	Height (cm)	Azimuth (deg.)	P/F	Remark
1	49.1865	-10.58	56.38	45.80	50.00	-4.20	QP			P	
2	54.8348	-12.38	58.68	46.30	50.00	-3.70	QP			P	
3	64.8865	-12.86	55.08	42.22	50.00	-7.78	QP			P	
4	146.3735	-6.17	50.73	44.56	50.00	-5.44	QP			P	
5	176.2684	-7.41	48.05	40.64	50.00	-9.36	QP			P	
6	250.3009	-4.12	49.26	45.14	57.00	-11.86	QP			P	

6. HARMONIC CURRENT EMISSION TEST

6.1 Block Diagram of Test Setup

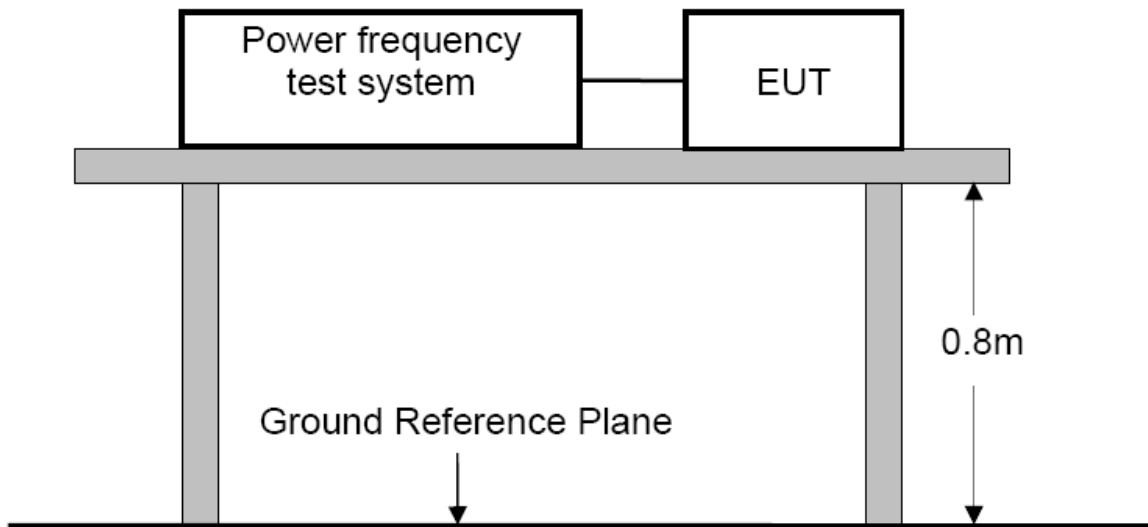

6.2 Limits of Harmonics current measurement

Test Standard: EN 61000-3-2

Limits for Class A equipment	
Harmonics Order n	Max. permissible harmonics current A
Odd harmonics	
3	2.30
5	1.14
7	0.77
9	0.40
11	0.33
13	0.21
$15 \leq n \leq 39$	$0.15 \times 15/n$
Even harmonics	
2	1.08
4	0.43
6	0.30
$8 \leq n \leq 40$	$0.23 \times 8/n$

For the following categories of equipment limits are not specified in this edition of the standard.

Note 1: Equipment with a rated power of 75W or less, other than lighting equipment.

6.3 Test Procedure

The E.U.T. was put on the top of a wooden table 0.8m above the ground and operated to produce the maximum harmonic components under normal operating conditions for each successive harmonic component in turn.

The E.U.T. is classified as follows:

Class A:

Balanced three-phase equipment, Household appliances excluding equipment as Class D, Tools excluding portable tools, Dimmers for incandescent lamps, audio equipment, equipment not specified in one of the three other classes.

Class B:

Portable tools; Arc welding equipment which is not professional equipment.

Class C:

Lighting equipment.

Class D:

Equipment having a specified power less than or equal to 600W of the following types: Personal computers and personal computer monitors and television receivers.

6.4 Operating Condition of E.U.T.

6.4.1 Setup the E.U.T. and simulators as shown in Section 2.3.

6.4.2 Turn on the power of all equipments.

6.4.3 Let the E.U.T. work in test mode (Normal operation mode) and test it.

6.5 Harmonics Current Measurement Result

PASS.

Please refer to the following pages.

Harmonics – Class-A per Ed. 4.0 (2014)(Run time)

EUT: FlinInfini Lite On-grid Inverter with Energy storage Tested by: Jerry
Test category: Class-A per Ed. 3.2 (2009) (European limits) Test Margin: 100
Test date: 2016-9-19 Start time: 20:34:15 End time: 20:37:07
Test duration (min): 2.5 Data file name: H-001665.cts_data
Comment: Normal operation mode
Customer: VOLTRONIC
Mode: FlinInfini Lite 2kW-24V
Test Result: Pass Source qualification: Normal

Current & voltage waveforms

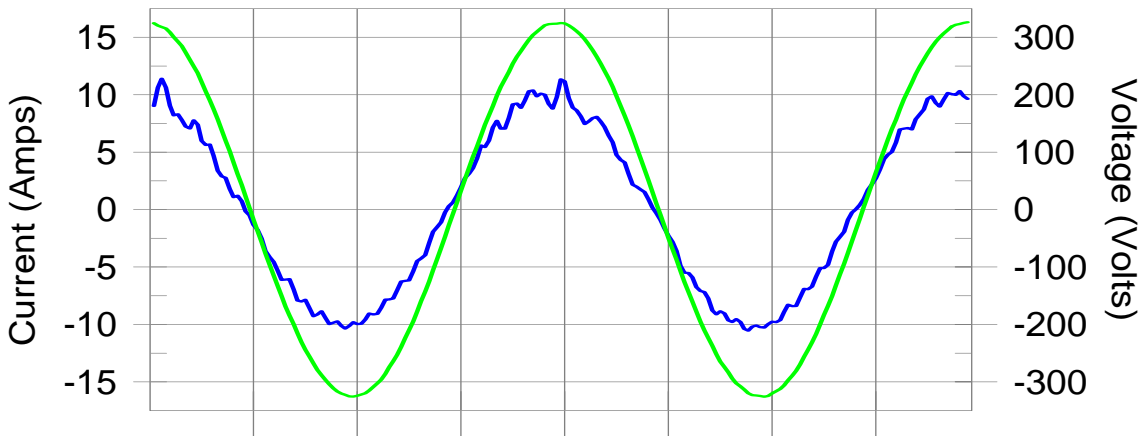

Harmonics and Class A limit line European Limits

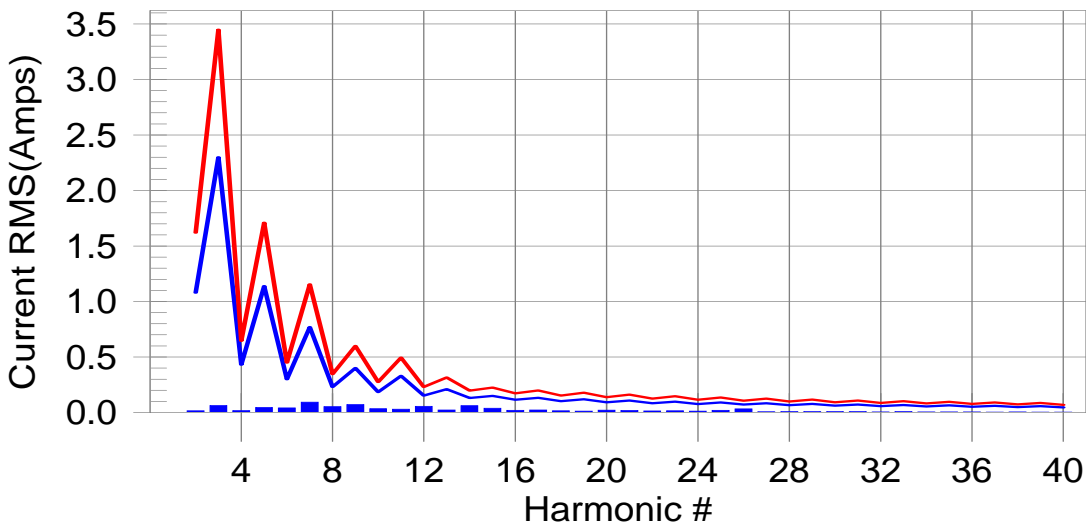

Test result: Pass Worst harmonic was #14 with 34.46% of the limit.

Current Test Result Summary (Run time)

EUT: FlinInfini Lite On-grid Inverter with Energy storage Tested by: Jerry
 Test category: Class-A per Ed. 3.2 (2009) (European limits) Test Margin: 100
 Test date: 2016-9-19 Start time: 20:34:15 End time: 20:37:07
 Test duration (min): 2.5 Data file name: H-001665.cts_data
 Comment: Normal operation mode
 Customer: VOLTRONIC
 Mode:FlinInfini Lite 2kW-24V
 Test Result: Pass Source qualification: Normal
 THC(A): 0.15 I-THD(%): 2.13 POHC(A): 0.000 POHC Limit(A): 0.320
 Highest parameter values during test:
 V_RMS (Volts): 230.20 Frequency(Hz): 50.00
 I_Peak (Amps): 11.680 I_RMS (Amps): 7.177
 I_Fund (Amps): 7.021 Crest Factor: 1.628
 Power (Watts): 2430.7 Power Factor: 0.993

Harm#	Harms(avg)	100%Limit	%of Limit	Harms(max)	150%Limit	%of Limit	Status
2	0.012	1.080	0.0	0.015	1.620	0.92	Pass
3	0.049	2.300	2.1	0.063	3.450	1.83	Pass
4	0.012	0.430	0.0	0.018	0.645	2.73	Pass
5	0.038	1.140	3.3	0.046	1.710	2.67	Pass
6	0.033	0.300	0.0	0.041	0.450	9.00	Pass
7	0.087	0.770	11.3	0.094	1.155	8.16	Pass
8	0.049	0.230	21.4	0.053	0.345	15.32	Pass
9	0.055	0.400	13.8	0.071	0.600	11.88	Pass
10	0.025	0.184	0.0	0.034	0.276	12.27	Pass
11	0.021	0.330	0.0	0.029	0.495	5.91	Pass
12	0.048	0.153	31.7	0.057	0.230	24.66	Pass
13	0.014	0.210	0.0	0.023	0.315	7.28	Pass
14	0.045	0.131	34.5	0.062	0.197	31.41	Pass
15	0.032	0.150	0.0	0.038	0.225	16.91	Pass
16	0.015	0.115	0.0	0.020	0.173	11.55	Pass
17	0.015	0.132	0.0	0.023	0.199	11.52	Pass
18	0.011	0.102	0.0	0.016	0.153	10.45	Pass
19	0.009	0.118	0.0	0.012	0.178	6.80	Pass
20	0.013	0.092	0.0	0.022	0.138	15.64	Pass
21	0.014	0.107	0.0	0.018	0.161	11.45	Pass
22	0.009	0.084	0.0	0.014	0.125	11.47	Pass
23	0.011	0.098	0.0	0.016	0.147	10.68	Pass
24	0.009	0.077	0.0	0.012	0.115	10.28	Pass
25	0.014	0.090	0.0	0.020	0.135	15.01	Pass
26	0.024	0.071	0.0	0.033	0.106	31.31	Pass
27	0.005	0.083	0.0	0.006	0.125	5.01	Pass
28	0.005	0.066	0.0	0.008	0.099	7.98	Pass
29	0.006	0.078	0.0	0.008	0.116	6.98	Pass
30	0.006	0.061	0.0	0.009	0.092	9.53	Pass
31	0.006	0.073	0.0	0.008	0.109	7.48	Pass
32	0.004	0.058	0.0	0.006	0.086	7.17	Pass
33	0.006	0.068	0.0	0.008	0.102	7.75	Pass
34	0.004	0.054	0.0	0.006	0.081	6.93	Pass
35	0.004	0.064	0.0	0.006	0.096	6.02	Pass
36	0.005	0.051	0.0	0.006	0.077	7.72	Pass
37	0.003	0.061	0.0	0.004	0.091	4.93	Pass
38	0.005	0.048	0.0	0.006	0.073	8.07	Pass
39	0.003	0.058	0.0	0.004	0.087	4.03	Pass
40	0.003	0.046	0.0	0.004	0.069	5.91	Pass

Voltage Source Verification Data (Run time)

EUT: FlinInfini Lite On-grid Inverter with Energy storage Tested by: Jerry
 Test category: Class-A per Ed. 3.2 (2009) (European limits) Test Margin: 100
 Test date: 2016-9-19 Start time: 20:34:15 End time: 20:37:07
 Test duration (min): 2.5 Data file name: H-001665.cts_data
 Comment: Normal operation mode
 Customer: VOLTRONIC
 Mode:FlinInfini Lite 2kW-24V
 Test Result: Pass Source qualification: Normal

Highest parameter values during test:

Voltage (Vrms):	230.20	Frequency(Hz):	50.00
I_Peak (Amps):	11.680	I_RMS (Amps):	7.177
I_Fund (Amps):	7.021	Crest Factor:	1.628
Power (Watts):	2430.7	Power Factor:	0.993

Harm#	Harmonics V-rms	Limit V-rms	% of Limit	Status
2	0.092	0.460	19.98	OK
3	0.580	2.071	28.03	OK
4	0.073	0.460	15.78	OK
5	0.096	0.920	10.40	OK
6	0.059	0.460	12.89	OK
7	0.050	0.690	7.21	OK
8	0.018	0.460	3.94	OK
9	0.032	0.460	7.01	OK
10	0.032	0.460	6.87	OK
11	0.026	0.230	11.33	OK
12	0.033	0.230	14.48	OK
13	0.020	0.230	8.49	OK
14	0.032	0.230	13.90	OK
15	0.024	0.230	10.43	OK
16	0.025	0.230	11.06	OK
17	0.015	0.230	6.33	OK
18	0.018	0.230	7.92	OK
19	0.013	0.230	5.69	OK
20	0.029	0.230	12.56	OK
21	0.021	0.230	8.99	OK
22	0.020	0.230	8.63	OK
23	0.016	0.230	7.16	OK
24	0.016	0.230	6.88	OK
25	0.044	0.230	19.02	OK
26	0.079	0.230	34.53	OK
27	0.012	0.230	5.07	OK
28	0.012	0.230	5.05	OK
29	0.011	0.230	4.77	OK
30	0.017	0.230	7.42	OK
31	0.011	0.230	4.62	OK
32	0.010	0.230	4.16	OK
33	0.011	0.230	4.66	OK
34	0.008	0.230	3.47	OK
35	0.011	0.230	4.95	OK
36	0.009	0.230	4.05	OK
37	0.007	0.230	3.10	OK
38	0.008	0.230	3.63	OK
39	0.010	0.230	4.52	OK
40	0.015	0.230	6.34	OK

Harmonics – Class-A per Ed. 4.0 (2014)(Run time)

EUT: FlinInfini Lite On-grid Inverter with Energy storage Tested by: Gavin
 Test category: Class-A per Ed. 4.0 (2014) (European limits) Test Margin: 100
 Test date: 2016-9-19 Start time: 14:36:41 End time: 14:39:33
 Test duration (min): 2.5 Data file name: H-000093.cts_data
 Comment: Normal operation mode
 Customer: VOLTRONIC
 M/N:FlinInfini Lite 1kW-12V
 Test Result: Pass Source qualification: Normal

Current & voltage waveforms

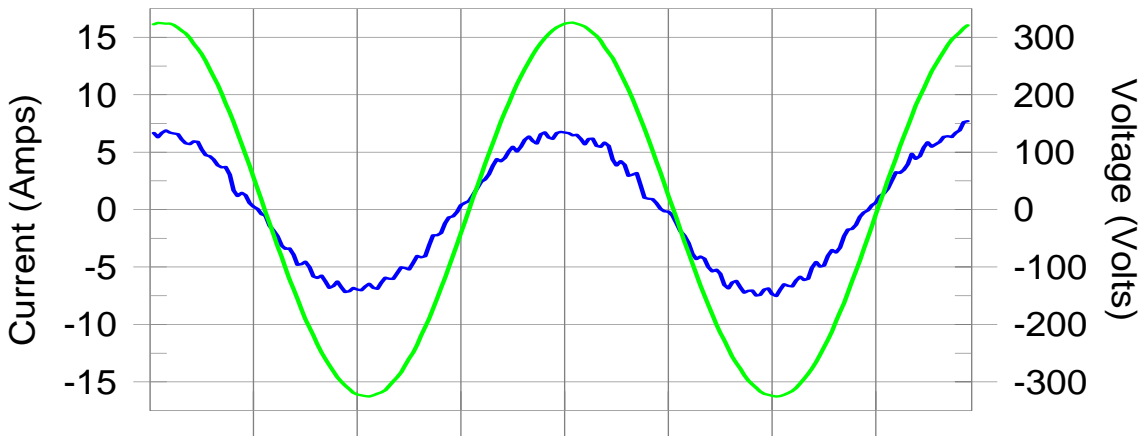

Harmonics and Class A limit line European Limits

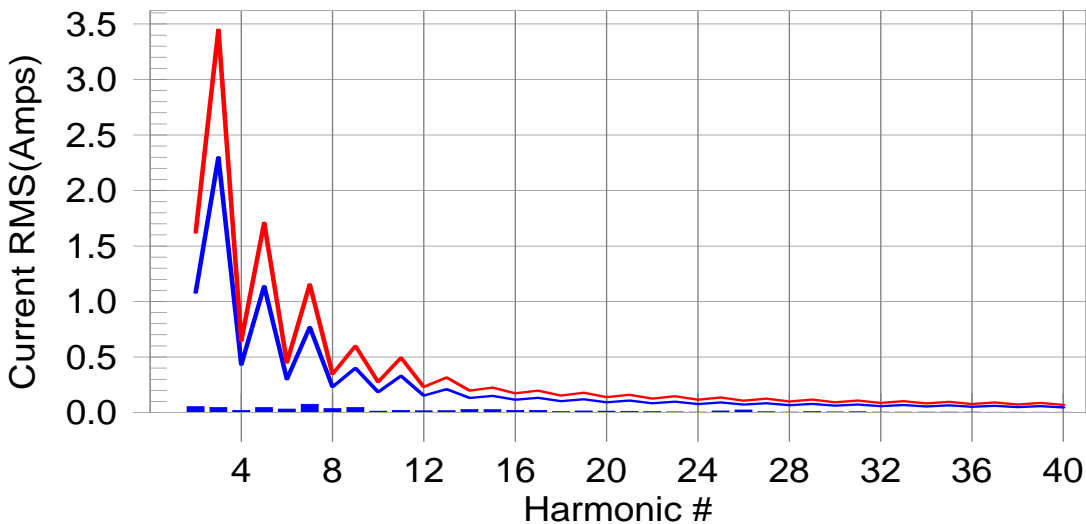

Test result: Pass Worst harmonic was #8 with 11.7% of the limit.

Current Test Result Summary (Run time)

EUT: FlinInfini Lite On-grid Inverter with Energy storage Tested by: Gavin
 Test category: Class-A per Ed. 4.0 (2014) (European limits) Test Margin: 100
 Test date: 2016-9-19 Start time: 14:36:41 End time: 14:39:33
 Test duration (min): 2.5 Data file name: H-000093.cts_data
 Comment: Normal operation mode
 Customer: VOLTRONIC
 M/N:FlinInfini Lite 1kW-12V
 Test Result: Pass Source qualification: Normal
 THC(A): 0.148 I-THD(%): 3.0 POHC(A): 0.000 POHC Limit(A): 0.251

Highest parameter values during test:

V_RMS (Volts): 230.25	Frequency(Hz): 50.00
I_Peak (Amps): 8.146	I_RMS (Amps): 4.994
I_Fund (Amps): 4.984	Crest Factor: 1.652
Power (Watts): 1350.5	Power Factor: 0.985

Harm#	Harms(avg)	100%Limit	%of Limit	Harms(max)	150%Limit	%of Limit	Status
2	0.053	1.080	4.9	0.057	1.620	3.5	Pass
3	0.045	2.300	1.9	0.051	3.450	1.5	Pass
4	0.020	0.430	N/A	0.028	0.645	N/A	Pass
5	0.045	1.140	3.9	0.053	1.710	3.1	Pass
6	0.031	0.300	10.5	0.037	0.450	8.3	Pass
7	0.075	0.770	9.7	0.080	1.155	6.9	Pass
8	0.036	0.230	15.5	0.040	0.345	11.7	Pass
9	0.046	0.400	11.4	0.060	0.600	10.1	Pass
10	0.012	0.184	N/A	0.021	0.276	N/A	Pass
11	0.020	0.330	N/A	0.024	0.495	N/A	Pass
12	0.016	0.153	N/A	0.024	0.230	N/A	Pass
13	0.017	0.210	N/A	0.031	0.315	N/A	Pass
14	0.027	0.131	N/A	0.037	0.197	N/A	Pass
15	0.025	0.150	N/A	0.039	0.225	N/A	Pass
16	0.020	0.115	N/A	0.032	0.173	N/A	Pass
17	0.019	0.132	N/A	0.035	0.198	N/A	Pass
18	0.008	0.102	N/A	0.015	0.153	N/A	Pass
19	0.014	0.118	N/A	0.019	0.178	N/A	Pass
20	0.013	0.092	N/A	0.023	0.138	N/A	Pass
21	0.011	0.107	N/A	0.017	0.161	N/A	Pass
22	0.008	0.084	N/A	0.014	0.125	N/A	Pass
23	0.006	0.098	N/A	0.008	0.147	N/A	Pass
24	0.004	0.077	N/A	0.007	0.115	N/A	Pass
25	0.014	0.090	N/A	0.018	0.135	N/A	Pass
26	0.023	0.071	N/A	0.032	0.107	N/A	Pass
27	0.007	0.083	N/A	0.009	0.125	N/A	Pass
28	0.004	0.066	N/A	0.006	0.099	N/A	Pass
29	0.008	0.078	N/A	0.011	0.116	N/A	Pass
30	0.006	0.061	N/A	0.009	0.092	N/A	Pass
31	0.007	0.073	N/A	0.011	0.109	N/A	Pass
32	0.004	0.058	N/A	0.006	0.086	N/A	Pass
33	0.005	0.068	N/A	0.007	0.102	N/A	Pass
34	0.004	0.054	N/A	0.006	0.081	N/A	Pass
35	0.004	0.064	N/A	0.007	0.096	N/A	Pass
36	0.004	0.051	N/A	0.005	0.077	N/A	Pass
37	0.003	0.061	N/A	0.004	0.091	N/A	Pass
38	0.003	0.048	N/A	0.005	0.073	N/A	Pass
39	0.003	0.058	N/A	0.004	0.087	N/A	Pass
40	0.003	0.046	N/A	0.005	0.069	N/A	Pass

Voltage Source Verification Data (Run time)

EUT: FlinInfini Lite On-grid Inverter with Energy storage Tested by: Gavin
 Test category: Class-A per Ed. 4.0 (2014) (European limits) Test Margin: 100
 Test date: 2016-9-19 Start time: 14:36:41 End time: 14:39:33
 Test duration (min): 2.5 Data file name: H-000093.cts_data
 Comment: Normal operation mode
 Customer: VOLTRONIC
 M/N:FlinInfini Lite 1kW-12V
 Test Result: Pass Source qualification: Normal

Highest parameter values during test:

Voltage (Vrms):	230.25	Frequency(Hz):	50.00
I_Peak (Amps):	8.146	I_RMS (Amps):	4.994
I_Fund (Amps):	4.984	Crest Factor:	1.652
Power (Watts):	1350.5	Power Factor:	0.985

Harm#	Harmonics V-rms	Limit V-rms	% of Limit	Status
2	0.091	0.460	19.71	OK
3	0.597	2.072	28.81	OK
4	0.101	0.460	21.90	OK
5	0.091	0.921	9.91	OK
6	0.056	0.460	12.27	OK
7	0.039	0.691	5.58	OK
8	0.031	0.460	6.71	OK
9	0.031	0.460	6.82	OK
10	0.024	0.460	5.18	OK
11	0.022	0.230	9.71	OK
12	0.014	0.230	6.12	OK
13	0.017	0.230	7.17	OK
14	0.022	0.230	9.51	OK
15	0.024	0.230	10.24	OK
16	0.027	0.230	11.71	OK
17	0.025	0.230	10.65	OK
18	0.014	0.230	5.95	OK
19	0.021	0.230	9.29	OK
20	0.031	0.230	13.41	OK
21	0.016	0.230	6.77	OK
22	0.020	0.230	8.69	OK
23	0.011	0.230	4.72	OK
24	0.014	0.230	6.02	OK
25	0.041	0.230	17.86	OK
26	0.080	0.230	34.93	OK
27	0.012	0.230	5.26	OK
28	0.010	0.230	4.50	OK
29	0.012	0.230	5.04	OK
30	0.019	0.230	8.07	OK
31	0.012	0.230	5.34	OK
32	0.009	0.230	3.98	OK
33	0.008	0.230	3.62	OK
34	0.008	0.230	3.39	OK
35	0.011	0.230	4.58	OK
36	0.008	0.230	3.65	OK
37	0.006	0.230	2.42	OK
38	0.007	0.230	2.93	OK
39	0.008	0.230	3.49	OK
40	0.014	0.230	6.30	OK

7. VOLTAGE FLUCTUATIONS & FLICKER TEST

7.1 Block Diagram of Test Setup

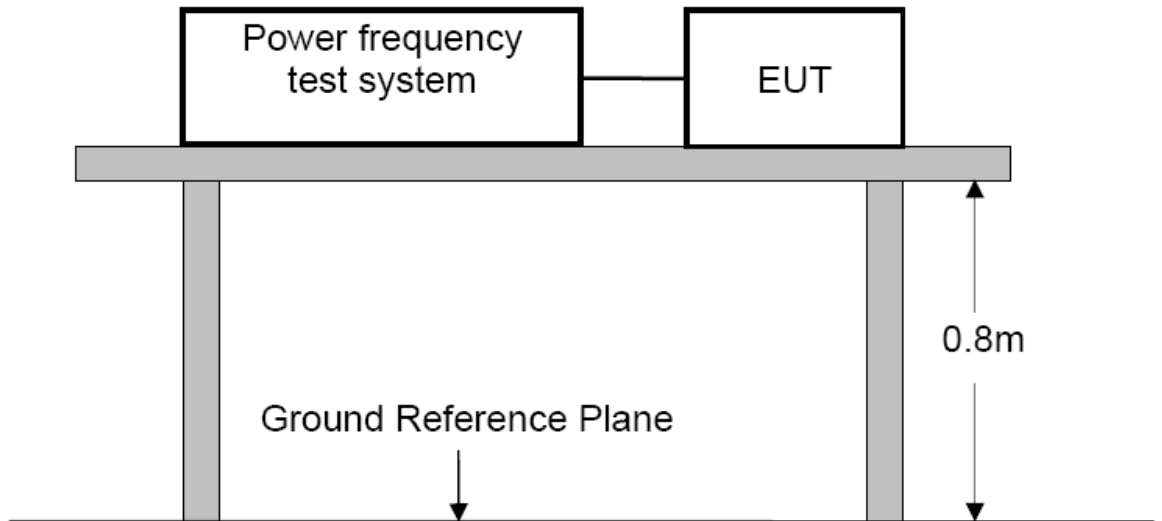

7.2 Limits of Voltage Fluctuations & Flicker Measurement

Test Standard: EN 61000-3-3

Test Item	Limit
P_{st} (Short-term flicker indicator.)	1.0
P_{lt} (Long-term flicker indicator.)	0.65
$T_{d(t)}$ (ms) (Maximum time that $d(t)$ exceeds 3.3%)	500
d_{max} (%) (Maximum relative voltage change.)	4
d_c (%) (Relative steady-state voltage change)	3.3

7.3 Test Procedure

The E.U.T. was put on the top of a wooden table 0.8m above the ground and operated to produce the most unfavorable sequence of voltage changes under normal operating conditions.

7.4 Operating Condition of E.U.T.

7.4.1 Setup the E.U.T. and simulators as shown in Section 2.3.

7.4.2 Turn on the power of all equipments.

7.4.3 Let the E.U.T. work in test mode (Normal operation mode) and test it.

7.5 Test Results

PASS.

Please refer to the following pages.

Flicker Test Summary per EN/IEC61000-3-3Ed. 3.0 (2013) (Run time)

EUT: FlinInfini Lite On-grid Inverter with Energy storage Tested by: Jerry
 Test category: All parameters (European limits) Test Margin: 100
 Test date: 2016-9-19 Start time: 20:39:58 End time: 20:50:19
 Test duration (min): 10 Data file name: F-001667.cts_data
 Comment: Normal operation mode
 Customer: VOLTRONIC
 Mode:FlinInfini Lite 2kW-24V
 Test Result: Pass Status: Test Completed

Pst_i and limit line

European Limits

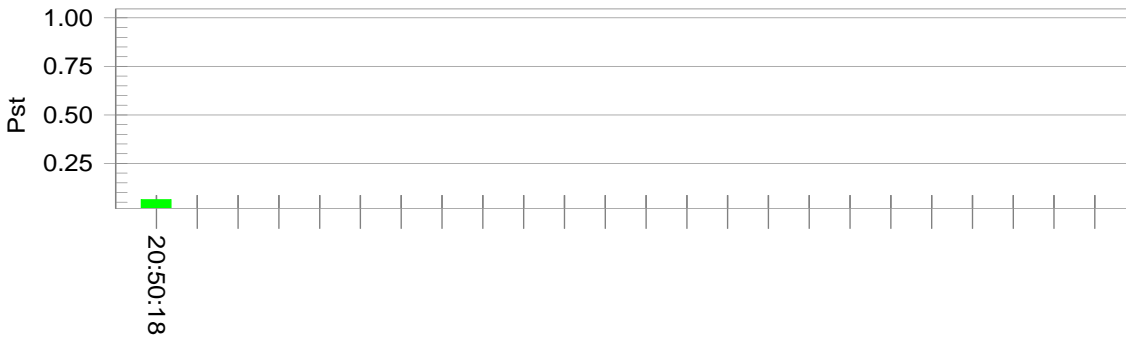

Plt and limit line

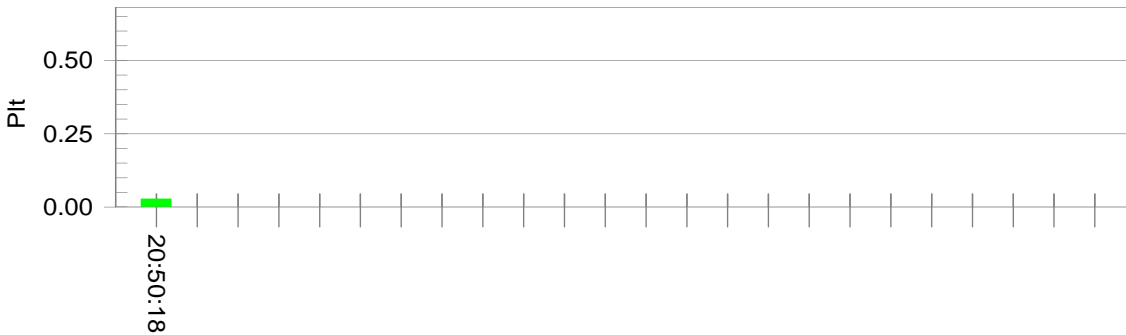

Parameter values recorded during the test:

Vrms at the end of test (Volt):	227.45			
Highest dt (%):	0.00	Test limit (%):	3.30	Pass
Time(mS) > dt:	0.0	Test limit (mS):	500.0	Pass
Highest dc (%):	0.00	Test limit (%):	3.30	Pass
Highest dmax (%):	0.00	Test limit (%):	4.00	Pass
Highest Pst (10 min. period):	0.064	Test limit:	1.000	Pass
Highest Plt (2 hr. period):	0.028	Test limit:	0.650	Pass

Flicker Test Summary per EN/IEC61000-3-3 Ed. 3.0 (2013) (Run time)

EUT: FlinInfini Lite On-grid Inverter with Energy storage Tested by: Gavin
 Test category: All parameters (European limits) Test Margin: 100
 Test date: 2016-9-19 Start time: 14:44:00 End time: 14:54:32
 Test duration (min): 10 Data file name: F-000094.cts_data
 Comment: Normal operation mode
 Customer: VOLTRONIC
 M/N: FlinInfini Lite 1kW-12V
 Test Result: Pass Status: Test Completed

Pst_i and limit line

European Limits

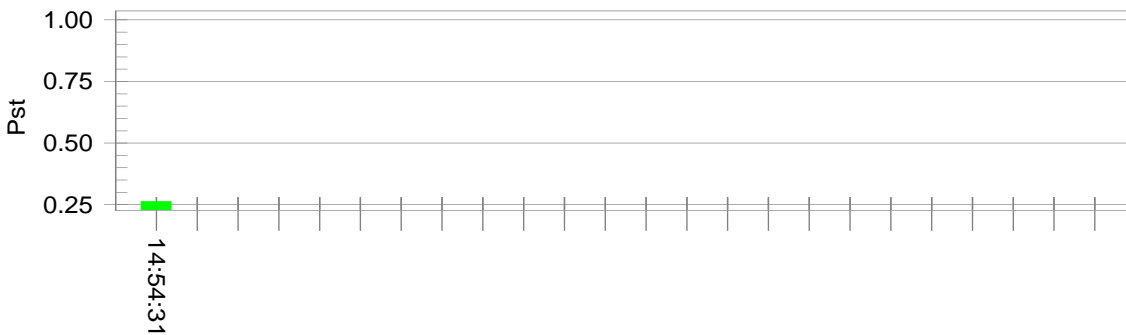

Plt and limit line

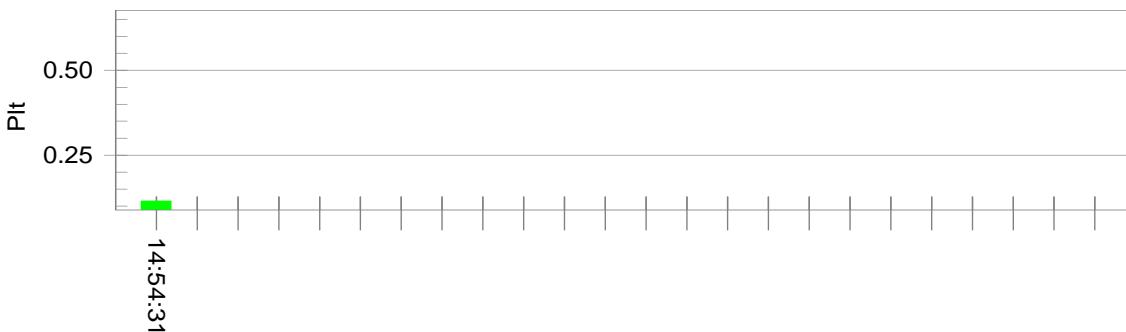

Parameter values recorded during the test:

Vrms at the end of test (Volt):	228.24			
Highest dt (%):	0.00	Test limit (%):	N/A	N/A
T-max (mS):	0	Test limit (mS):	500.0	Pass
Highest dc (%):	0.00	Test limit (%):	3.30	Pass
Highest dmax (%):	-0.06	Test limit (%):	4.00	Pass
Highest Pst (10 min. period):	0.263	Test limit:	1.000	Pass
Highest Plt (2 hr. period):	0.115	Test limit:	0.650	Pass

8. PERFORMANCE CRITERIA FOR IMMUNITY

The performance criteria are referred to the test standard: EN 61000-6-2

The variety and the diversity of the apparatus within the scope of this standard makes it difficult to define precise criteria for the evaluation of the immunity test results. If, as a result of the application of the tests defined in this standard, the apparatus becomes dangerous or unsafe, the apparatus shall be deemed to have failed the test. A functional description and a definition of performance criteria, during or as a consequence of the EMC testing, shall be provided by the manufacturer and noted in the test report.

Performance Criterion A:

The apparatus shall continue to operate as intended during and after the test. No degradation of performance or loss of function is allowed below a performance level specified by the manufacturer, when the apparatus is used as intended. The performance level may be replaced by a permissible loss of performance. If the minimum performance level or the permissible performance loss is not specified by the manufacturer, either of these may be derived from the product description and documentation and what the user may reasonable expect from the apparatus if used as intended.

Performance Criterion B:

The apparatus shall continue to operate as intended after the test. No degradation of performance or loss of function is allowed below a performance level specified by the manufacturer, when the apparatus is used as intended. The performance level may be replaced by a permissible loss of performance. During the test, degradation of performance is however allowed. No change of actual operation state or stored data is allowed. If the minimum performance level or the permissible performance loss is not specified by the manufacturer, either of these may be derived from the product description and documentation and what the user may reasonably expect from the apparatus if used as intended.

Performance Criteria C

Temporary loss of function is allowed, provided the function is self-recoverable or can be restored by the operation of the controls.

9. ELECTROSTATIC DISCHARGE TEST

9.1 Block Diagram of Test Setup

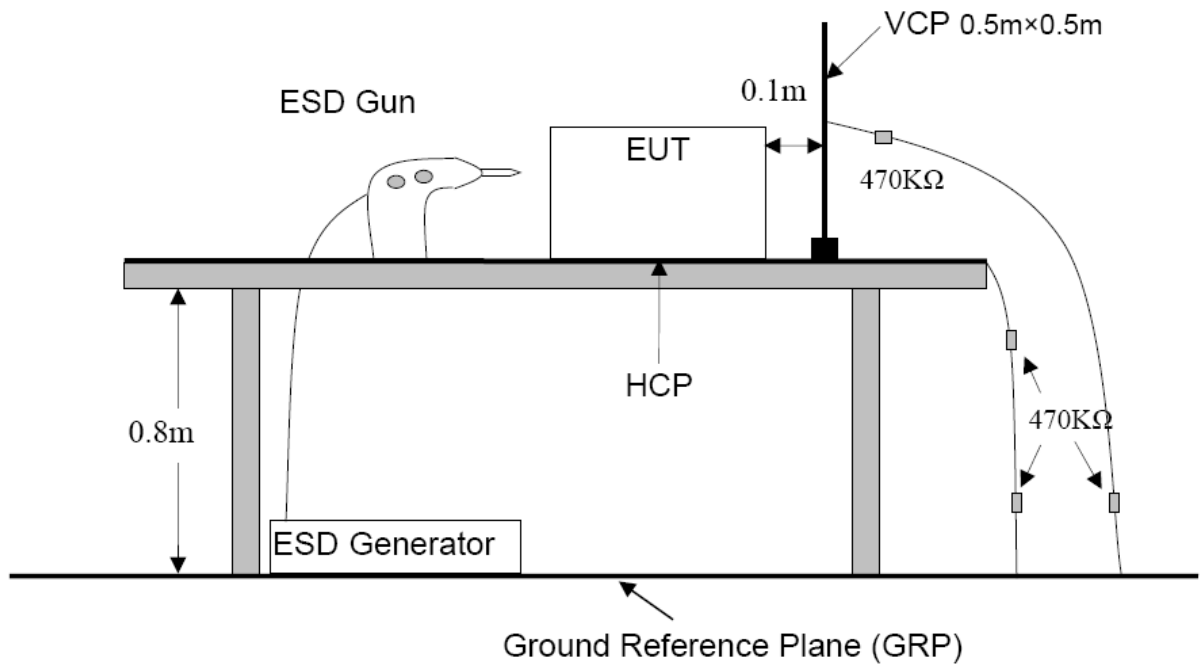

9.2 Test Standard and Severity Levels

9.2.1 Test Standard:

EN 61000-6-2

(EN 61000-4-2 Air Discharge: Severity Level: 3, ± 8KV;

Contact Discharge: Level: 2, ± 4KV)

9.2.2 Severity Levels:

Level	Test Voltage Contact Discharge (KV)	Test Voltage Air Discharge (KV)
1.	±2	±2
2.	±4	±4
3.	±6	±8
4.	±8	±15
X	Special	Special

9.3 Test Procedure

9.3.1 Air Discharge:

This test is done on a non-conductive surface. The round discharge tip of the discharge electrode shall be approached as fast as possible to touch the E.U.T.. After each discharge, the discharge electrode shall be removed from the E.U.T.. The generator is then re-triggered for a new single discharge and repeated 10 times for each pre-selected test point. This procedure shall be repeated until all the air discharge completed

9.3.2 Contact Discharge:

All the procedure shall be same as Section 9.3.1. except that the tip of the discharge electrode shall touch the E.U.T..

9.3.3 Indirect discharge for horizontal coupling plane

At least 10 single discharges(in the most sensitive polarity) shall be applied at the front edge of each HCP opposite the center point of each unit(if applicable) of the E.U.T. and 0.1m from the front of the E.U.T.. The long axis of the discharge electrode shall be in the plane of the HCP and perpendicular to its front edge during the discharge.

9.3.4 Indirect discharge for vertical coupling plane

At least 10 single discharge (in the most sensitive polarity) shall be applied to the center of one vertical edge of the coupling plane. The coupling plane, of dimensions 0.5m X 0.5m, is placed parallel to, and positioned at a distance of 0.1m from the E.U.T.. Discharges shall be applied to the coupling plane, with this plane in sufficient different positions that the four faces of the E.U.T. are completely illuminated.

9.4 Test Results

PASS.

Please refer to the following page.

Electrostatic Discharge Test Results

Ambient Condition:	Temp.: 25 °C	R.H.: 51 %	Air Pressure: 101 kPa
Power Supply:	AC 230V/50Hz; DC 12V or DC 24V; PV: DC 72V	Required Performance Criterion: B	
Test Specifications:	±2, 4 kV Contact Discharge; ±2, 4, 8 kV Air Discharge For each point positive 10 times and negative 10 times		
Tested mode:	Normal operation mode, Stored energy operation mode, Normal operation mode+PV		
Test Point	Kind A-Air Discharge C-Contact Discharge	Result (Performance Criterion)	
Slot of EUT	A	A	
Screen	A	A	
Metal	C	A	
Button	A	A	
Indirect Discharge (HCP)	C	A	
Indirect Discharge (VCP)	C	A	
Note:			
Test Equipment : ESD Tester (TESEQ, NSG 437)		Test Engineer : Stan	

10. RF FIELD STRENGTH SUSCEPTIBILITY TEST

10.1 Block Diagram of Test Setup

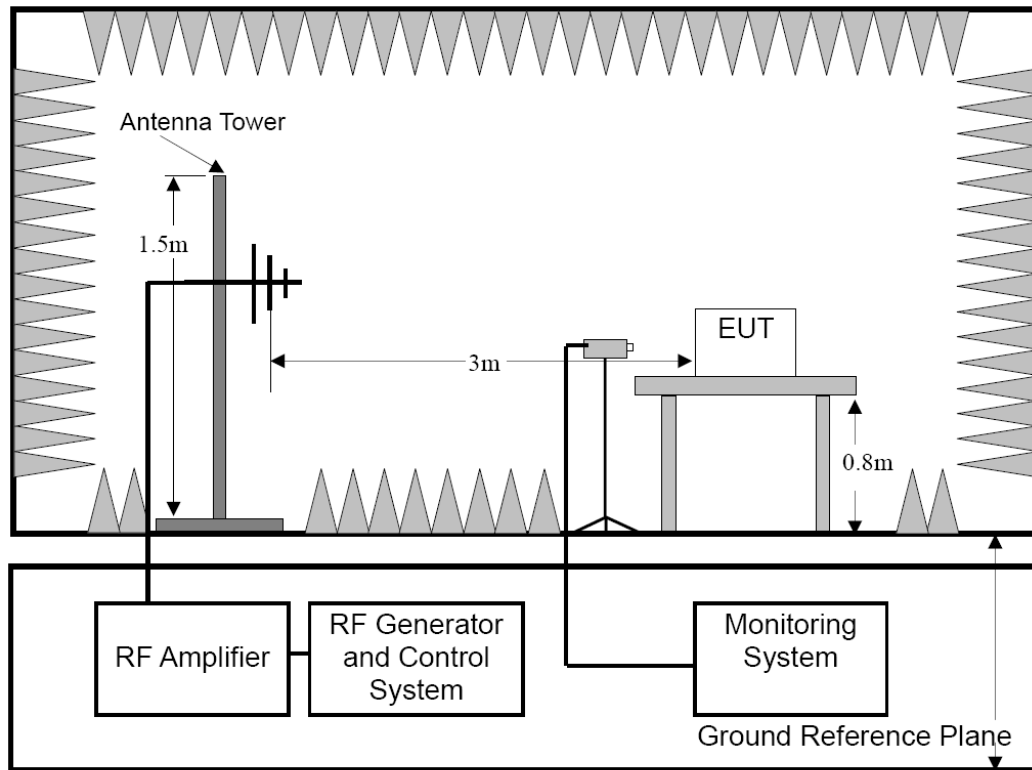

10.2 Test Standard and Severity Levels

10.2.1 Test Standard

EN 61000-6-2

(EN 61000-4-3,

80 to 1000MHz Severity Level: 3, 10V/m;

1.4 to 2.0GHz Severity Level: 2, 3V/m;

2.0 to 2.7GHz Severity Level: 1, 1V/m)

10.2.2 Severity Levels

Level	Field Strength V/m
1.	1
2.	3
3.	10
X	Special

10.3 Test Procedure

The E.U.T. and its simulators are placed on a turn table which is 0.8 meter above ground. E.U.T. is set 3 meter away from the transmitting antenna which is mounted on an antenna tower. Both horizontal and vertical polarization of the antenna are set on test. Each of the four sides of E.U.T. must be faced this transmitting antenna and measured individually.

All the scanning conditions are as follows :

Condition of Test	Remarks
1. Fielded Strength	80 to 1000MHz Severity Level: 3, 10V/m; 1.4 to 2.0GHz Severity Level: 2, 3V/m; 2.0 to 2.7GHz Severity Level: 1, 1V/m
2. Radiated Signal	Modulated
3. Dwell time of radiated	0.0015 decade/s
4. Waiting Time	1 Sec.

10.4 Test Results

PASS.

Please refer to the following page.

RF Field Strength Susceptibility Test Results

Ambient Condition:	Temp.: 25 °C	R.H.: 51 %	Air Pressure: 101 kPa	
Power Supply:	AC 230V/50Hz; DC 12V or DC 24V; PV: DC 72V	Required Performance Criterion: A		
Test Specifications:	Modulation: 1kHz, 80%AM; Step Size: 1%; Dwell Time: 1s			
Tested mode:	Normal operation mode, Stored energy operation mode, Normal operation mode+PV			
Frequency (MHz)	Level (V/m)	Antenna polarity	Side	Result (Performance Criterion)
80-1000	10	Horizontal/ Vertical	Front/ Left/ Right/ Back	A
1400-2000	3			A
2000-2700	1			A
Note:				
Test Equipment : 1. RF Power Meter : 4242 (ESE) 2. Power Amplifier : CBA 1G-150 (TESEQ) 3. Power Sensor: 51011EMC(ESE) 4. Antenna: VULB9162 (Schwarzbeck)				
				Test Engineer : Stan

11.ELECTRICAL FAST TRANSIENT/BURST TEST

11.1 Block Diagram of Test Setup

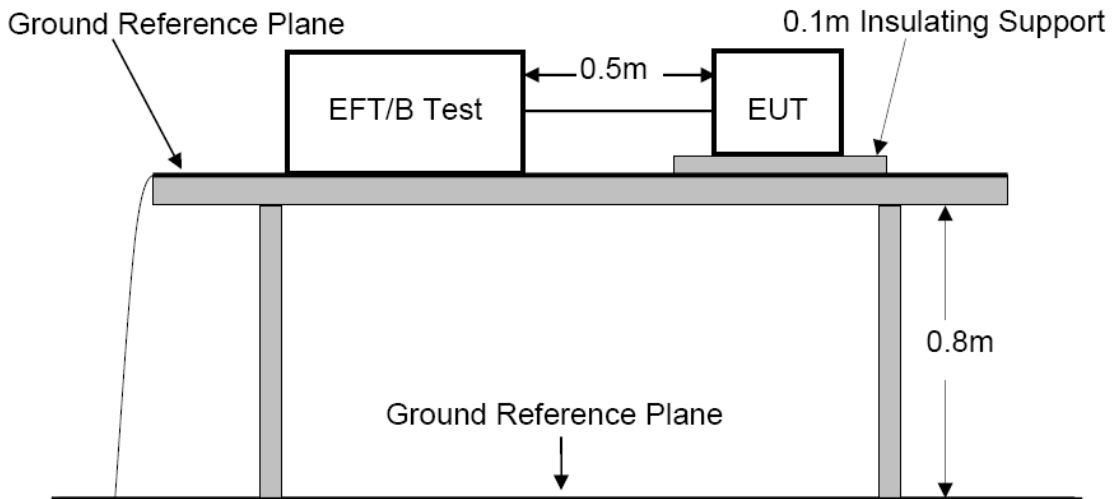

11.2 Test Standard and Severity Levels

11.2.1 Test Standard

EN 61000-6-2

(EN 61000-4-4, Severity Level, Level 3: 2KV)

11.2.2 Severity level

Open circuit output test voltage and repetition rate of the impulses				
Level	On power port, PE		On I/O (Input/Output) Signal data and control ports	
	Voltage peak KV	Repetition rate KHz	Voltage peak KV	Repetition rate KHz
1.	0.5	5 or 100	0.25	5 or 100
2.	1.0	5 or 100	0.5	5 or 100
3.	2.0	5 or 100	1.0	5 or 100
4.	4.0	5 or 100	2.0	5 or 100
X	Special	Special	Special	Special

Note 1 Use of 5 KHz repetition rates is traditional; however, 100 KHz is closer to reality. Product committees should determine which frequencies are relevant for specific products or product types.

Note 2 With some products, there may be no clear distinction, between power ports and I/O ports, in which case it is up to product committees to make this determination for test purposes.

Note 3 "X" is an open level. The level has to be specified in the dedicated equipment specification.

11.3 Test Procedure

The E.U.T. is put on the table which is 0.8 meter high above the ground. This reference ground plane shall project beyond the E.U.T. by at least 0.1m on all sides and the minimum distance between E.U.T. and all other conductive structure, except the ground plane beneath the E.U.T., shall be more than 0.5m.

11.3.1 For input and output AC power ports:

The E.U.T. is connected to the power mains by using a coupling device which couples the EFT interference signal to AC power lines. Both polarities of the test voltage should be applied during compliance test and the duration of the test is 2 minutes.

11.3.2 For signal lines ports:

It's unnecessary to test.

11.3.3 For DC ports:

It's unnecessary to test.

11.4 Test Result

PASS.

Please refer to the following page.

Electrical Fast Transient/Burst Test Results

Ambient Condition:	Temp.: 25 °C	R.H.: 51 %	Air Pressure: 101 kPa
Power Supply:	AC 230V 50Hz	Required Performance Criterion: B	
Test Specifications:	Repetition Frequency: 5kHz; Duration: 15ms; Period: 300ms		
Test mode:	Normal operation mode		
Line :	<input checked="" type="checkbox"/> AC Mains	<input type="checkbox"/> Signal line	<input type="checkbox"/> DC line
Coupling :	<input checked="" type="checkbox"/> Direct	<input type="checkbox"/> Capacitive	
Line	Test Voltage	Result (Performance Criterion)	
L	±2KV	A	
N	±2KV	A	
PE	±2KV	A	
L ∙ N	±2KV	A	
L ∙ PE	±2KV	A	
N ∙ PE	±2KV	A	
L ∙ N ∙ PE	±2KV	A	
Signal line			
DC line			
Note :			
Test Equipment : Burst Tester(EM TEST, UCS500N)		Test Engineer : Stan	

12. SURGE IMMUNITY TEST

12.1 Block Diagram of Test Setup

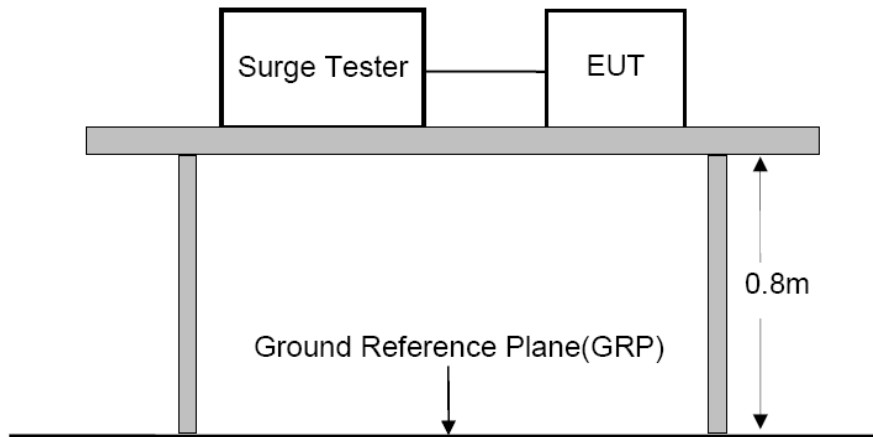

12.2 Test Standard and Severity Levels

12.2.1 Test Standard

EN 61000-6-2

(EN 61000-4-5, Severity Level: Line To Line, Level 2: 1.0KV
 Line To Earth, level 3: 2.0KV)

12.2.2 Severity level

Severity Level	Open-Circuit Test Voltage KV
1	0.5
2	1.0
3	2.0
4	4.0
*	Special

12.3 Test Procedure

1. Set up the E.U.T. and test generator as shown on Section 12.1.
2. For line to line coupling mode, provide a 1.0KV 1.2/50us voltage surge (at open-circuit condition) and 8/20us current surge to E.U.T. selected points. For line to earth coupling mode, provide a 2.0KV 1.2/50us voltage surge (at open-circuit condition) and 8/20us current surge to E.U.T. selected points.

3. At least 5 positive and 5 negative (polarity) tests with a maximum 1/min repetition rate are conducted during test.
4. Different phase angles are done individually.
5. Record the E.U.T. operating situation during compliance test and decide the E.U.T. immunity criterion for above each test.

12.4 Test Result

PASS.

Please refer to the following page.

Surge Immunity Test Results

Ambient Condition:	Temp.: 25 °C	R.H.: 51 %	Air Pressure: 101 kPa
Power Supply:	AC 230V 50Hz	Required Performance Criterion: B	
Test Specifications:	Voltage surge 1.2/50 us ; Current surge 8/20 us .		
Test mode:	Normal operation mode		
Line	Phase Angle	Test Voltage	Result (Performance Criterion)
L-N	0°, 90°, 180°, 270°	±1KV	A
L-PE	0°, 90°, 180°, 270°	±2KV	A
N-PE	0°, 90°, 180°, 270°	±2KV	A
Signal line			
DC line			
Note :			
Test Equipment : Burst Tester(EM TEST, UCS500N)		Test Engineer : Stan	

13. INJECTED CURRENTS SUSCEPTIBILITY TEST

13.1 Block Diagram of Test Setup

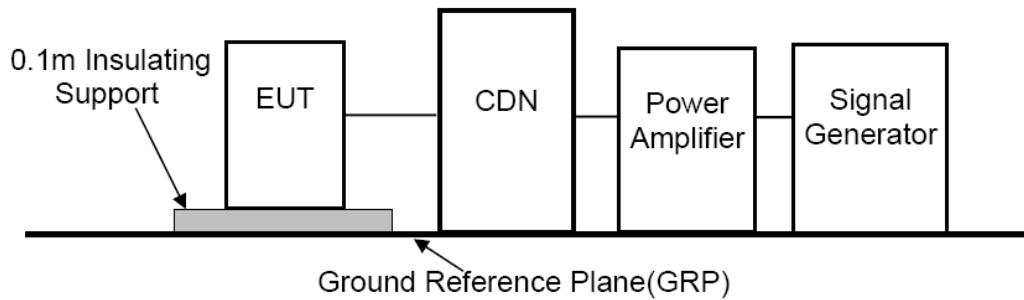

13.2 Test Standard and Severity Levels

13.2.1 Test Standard

EN 61000-6-2

(EN 61000-4-6, Severity Level 3: 10V (rms), 0.15MHz ~ 80MHz)

13.2.2 Severity level

Level	Field Strength V
1.	1
2.	3
3.	10
X	Special

13.3 Test Procedure

1. Set up the E.U.T., CDN and test generators as shown on Section 13.1.
2. Let the E.U.T. work in test mode and measure it.
3. The E.U.T. are placed on an insulating support 0.1m high above a ground reference plane. CDN (coupling and decoupling device) is placed on the ground plane about 0.3m from E.U.T.. Cables between CDN and E.U.T. are as short as possible, and their height above the ground reference plane shall be between 30 and 50 mm (where possible).
4. The disturbance signal described below is injected to E.U.T. through CDN.
5. The E.U.T. operates within its operational mode(s) under intended climatic conditions after power on.
6. The frequency range is swept from 150 KHz to 80 MHz using 10V signal level, and with the disturbance signal 80% amplitude modulated with a 1KHz sine wave.
7. The rate of sweep shall not exceed 1.5×10^{-3} decades/s. Where the frequency is swept incrementally, the step size shall not exceed 1% of the start and thereafter 1% of the preceding frequency value.
8. Recording the E.U.T. operating situation during compliance testing and decide the E.U.T. immunity criterion.

13.4 Test Result

PASS.

Please refer to the following page.

Injected Currents Susceptibility Test Results

Ambient Condition:	Temp.: 25 °C	R.H.: 51 %	Air Pressure: 101 kPa
Power Supply:	AC 230V 50Hz	Required Performance Criterion: A	
Test Specifications:	Modulation : 1KHz, 80%AM, Step Size : 1%, Dwell Time : 3s		
Test mode:	Normal operation mode		
Test Port	Frequency (MHz)	Level(V)	Result (Performance Criterion)
AC Mains	0.15~80	10	A
Note :			
Test Equipment : CDN (Luthi, L-801M2/M3)		Test Engineer : Stan	

14.VOLTAGE DIPS AND INTERRUPTIONS TEST

14.1 Block Diagram of Test Setup

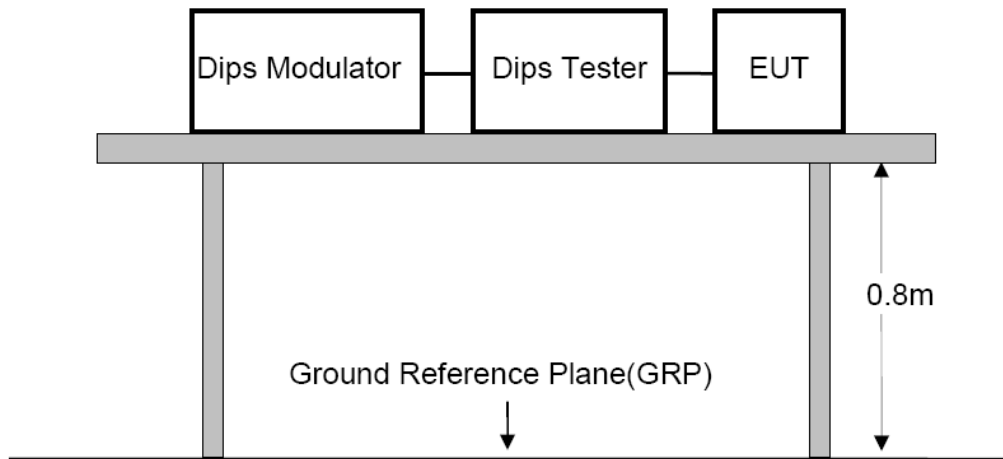

14.2 Test Standard and Severity Levels

14.2.1 Test Standard

EN 61000-6-2
 (EN 61000-4-11)

14.2.2 Severity level

Test Level %U _T	Voltage dip and short interruptions %U _T	Duration (in period)
0	100	0.5
40	60	1
70	30	5
		10
		25
		50
		*

14.3 Test Procedure

1. Set up the E.U.T. and test generator as shown on Section 14.1.
2. The interruption is introduced at selected phase angles with specified duration.
3. Record any degradation of performance.

14.4 Test Result

PASS.

Please refer to the following page.

Voltage Dips And Interruptions Test Results

Ambient Condition:	Temp.: 25 °C	R.H.: 51 %	Air Pressure: 101 kPa
Power Supply:	AC 230V 50Hz	Required Performance Criterion: B & C	
Test Specifications:	0%U _T , 1Cycle; 40%U _T , 10/12Cycles at 50/60Hz ; 70% U _T , 25/30Cycles at 50/60Hz; 0%U _T , 250/300Cycles at 50/60Hz;		
Test mode:	Normal operation mode		
Test Level % UT	Duration (in period)		Result (Performance Criterion)
	50Hz	60Hz	
0	1	--	A
40	10	--	A
70	25	--	A
0	250	--	B
Note : The EUT change to battery mode automatically, and it can be recovered itself after test.			
Test Equipment : Dips Tester: EM TEST, UCS 500N		Test Engineer : Stan	

15.MAGNETIC FIELD IMMUNITY TEST

15.1 Block Diagram of Test Setup

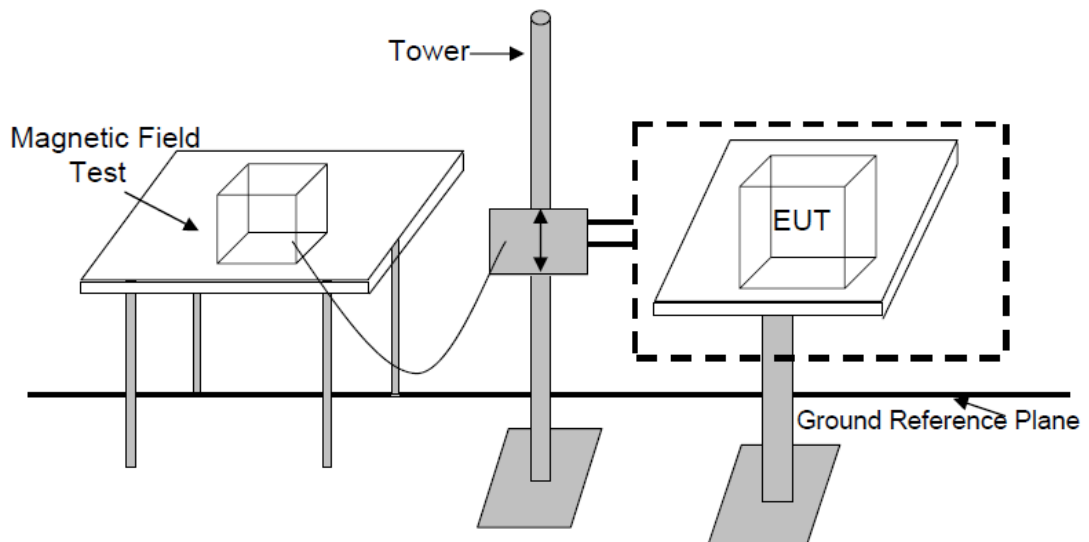

15.2 Test Standard and Severity Levels

15.2.1 Test Standard

EN 61000-6-2

(EN 61000-4-8: 2010, Severity level 4: 30A/m)

15.2.2 Severity level

Level	Magnetic Field Strength A/m
1	1
2	3
3	10
4	30
5	100
X	Special

15.3 Test Procedure

The E.U.T. is placed in the middle of a induction coil (1*1m), under which is a 1*1*0.1m (high) table, this small table is also placed on a larger table, 0.8m above the ground. X, Y and Z polarization of the induction coil are set on test, so that each side of the E.U.T. is affected by the magnetic field. Also can reach the same aim by change the position of the E.U.T..

15.4 Test Result

PASS.

Please refer to the following page.

Magnetic Field Immunity Test Results

Ambient Condition:	Temp.: 25 °C	R.H.: 51 %	Air Pressure: 101 kPa
Power Supply:	AC 230V/50Hz; DC 12V or DC 24V; PV: DC 72V	Required Performance Criterion: A	
Test Specifications:	30A/m 50/60Hz		
Test mode:	Normal operation mode		
Test Level	Testig Duration	Coil Orientati on	Result (Performance Criterion)
30A/m	5min	X	A
30A/m	5min	Y	A
30A/m	5min	Z	A
Note :			
Test Equipment : Magnetic Field Tester (EMC PARTNER, TRA2000) Test Engineer : Stan			

16.PHOTOGRAPH

16.1 Photo of Conducted Emission Measurement

M/N: FlinInfini Lite 2kW-24V



16.2 Photo of Conducted Emission Measurement

M/N: FlinInfini Lite 1kW-12V



16.3 Photo of Radiation Emission Measurement

M/N: FlinInfini Lite 2kW-24V



16.4 Photo of Radiation Emission Measurement

M/N: FlinInfini Lite 1kW-12V



16.5 Photo of Harmonic/Flicker Measurement

M/N: FlinInfini Lite 2kW-24V

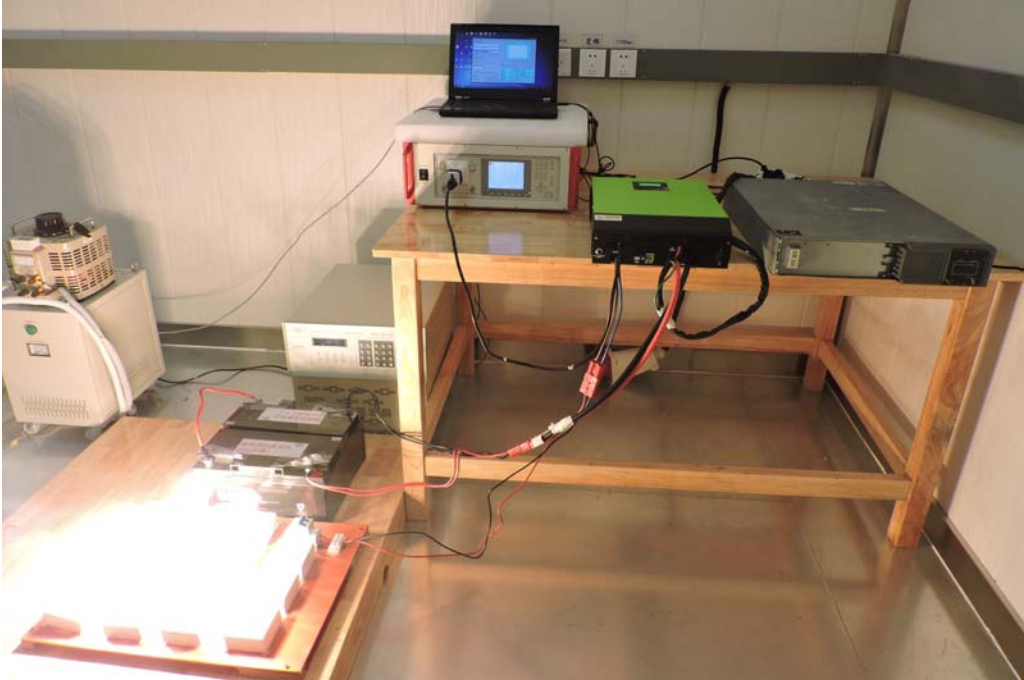

16.6 Photo of Harmonic/Flicker Measurement

M/N: FlinInfini Lite 1kW-12V

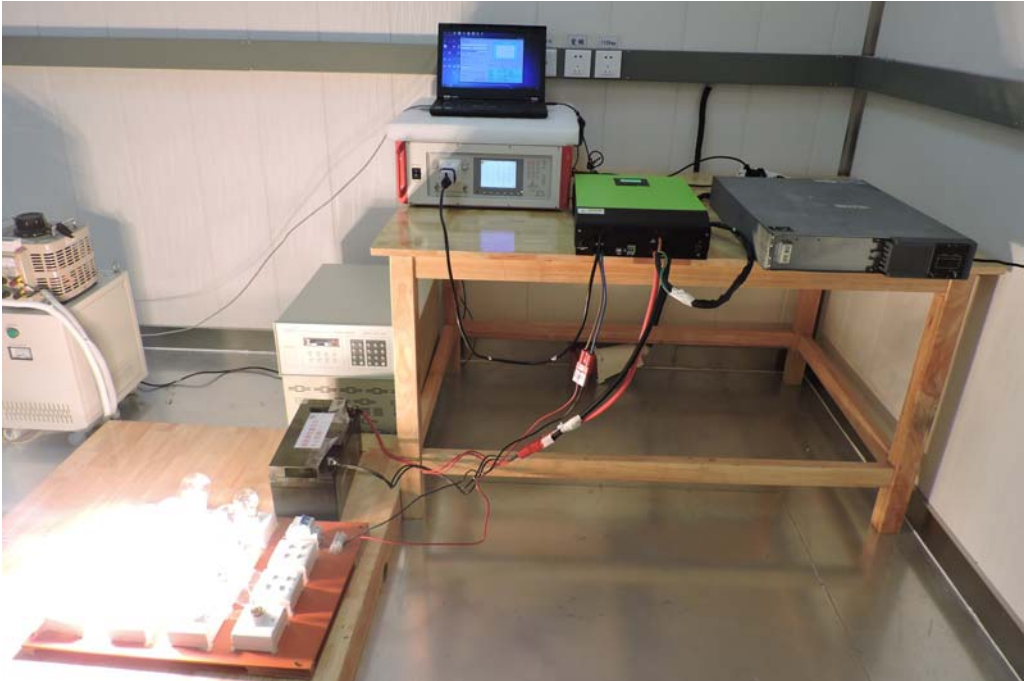

16.7 Photo of Electrostatic Discharge Test

M/N: FlinInfini Lite 2kW-24V

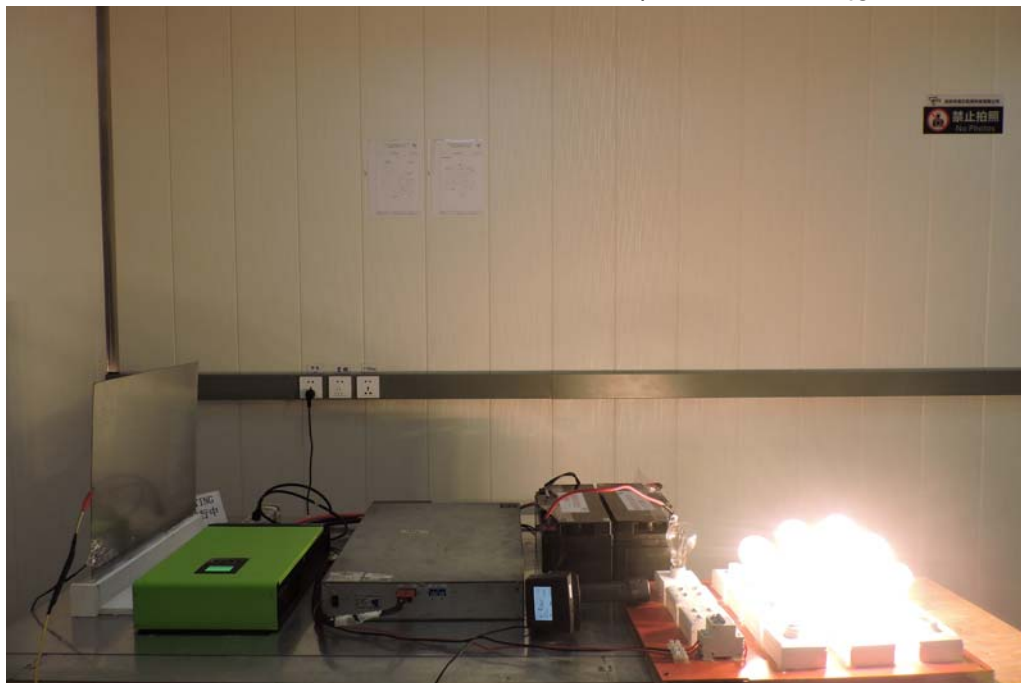

16.8 Photo of Electrostatic Discharge Test

M/N: FlinInfini Lite 1kW-12V



16.9 Photo of Electrical Fast Transient /Surge /Voltage Dips Test

M/N: FlinInfini Lite 2kW-24V

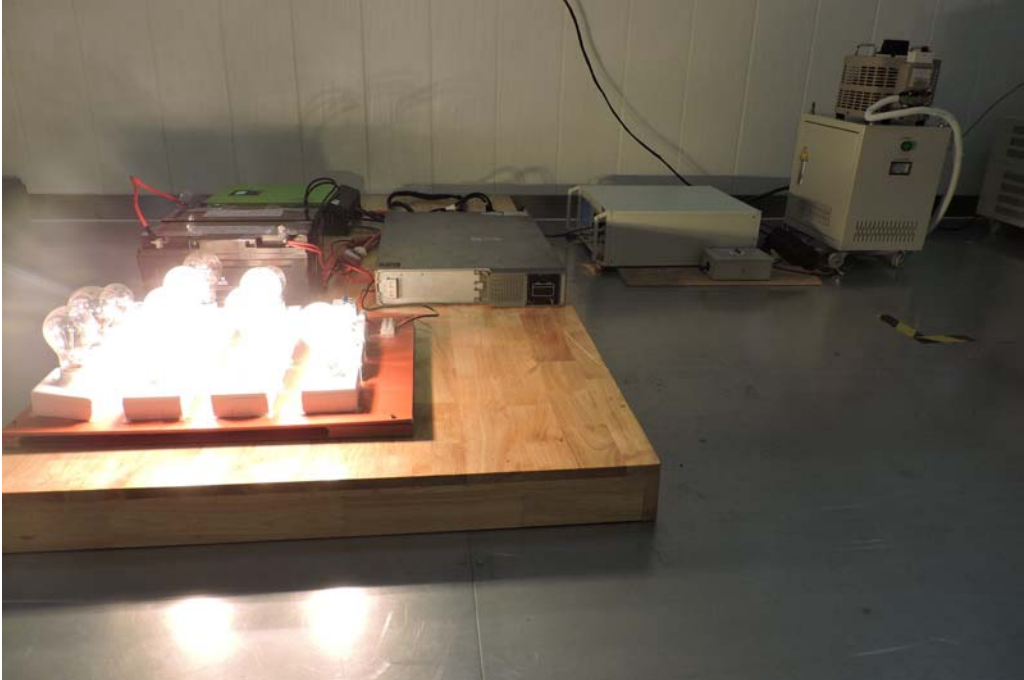

16.10 Photo of Electrical Fast Transient /Surge /Voltage Dips Test

M/N: FlinInfini Lite 1kW-12V

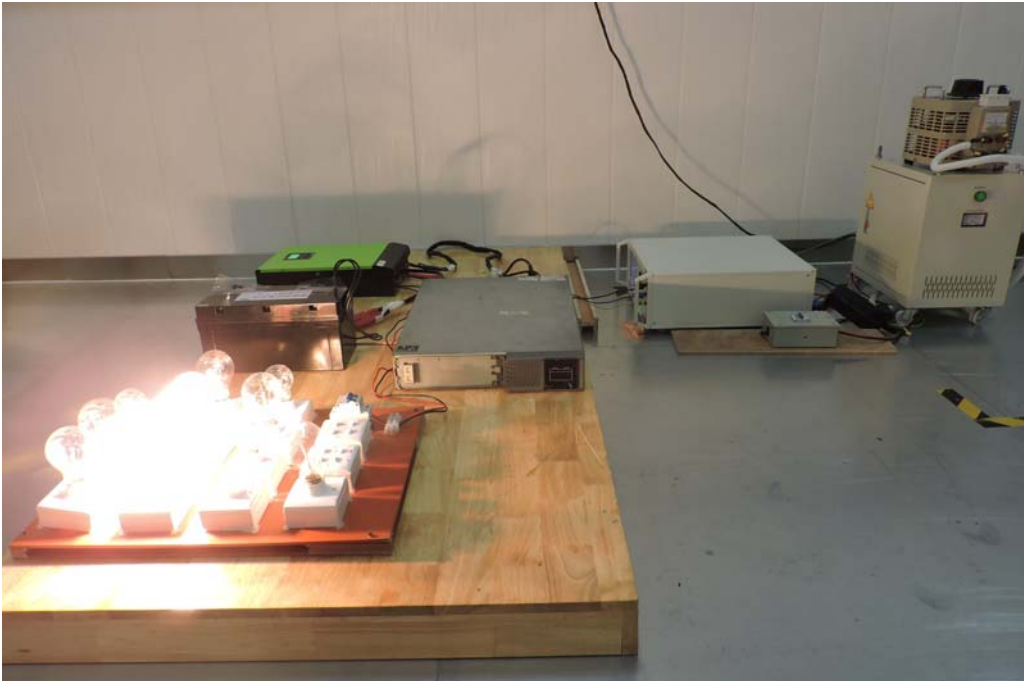

APPENDIX I (Photos of E.U.T.)

Figure 1
General Appearance of the E.U.T.
M/N: FlinInfini Lite 2kW-24V

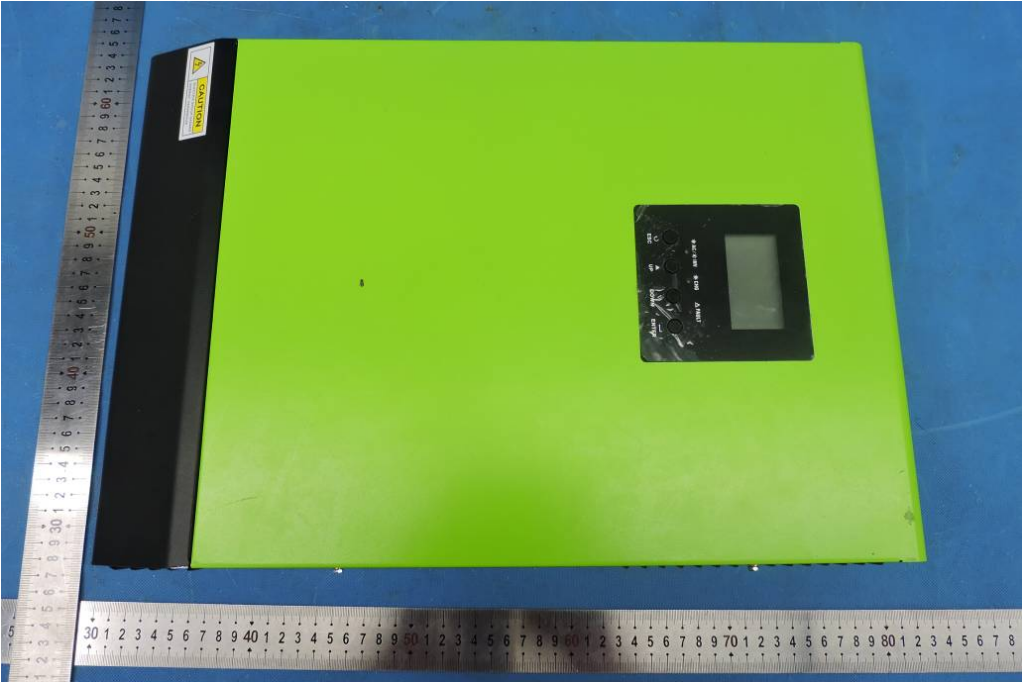

Figure 2
General Appearance of the E.U.T.
M/N: FlinInfini Lite 2kW-24V



Figure 3
General Appearance of the E.U.T.
M/N: FlinInfini Lite 2kW-24V

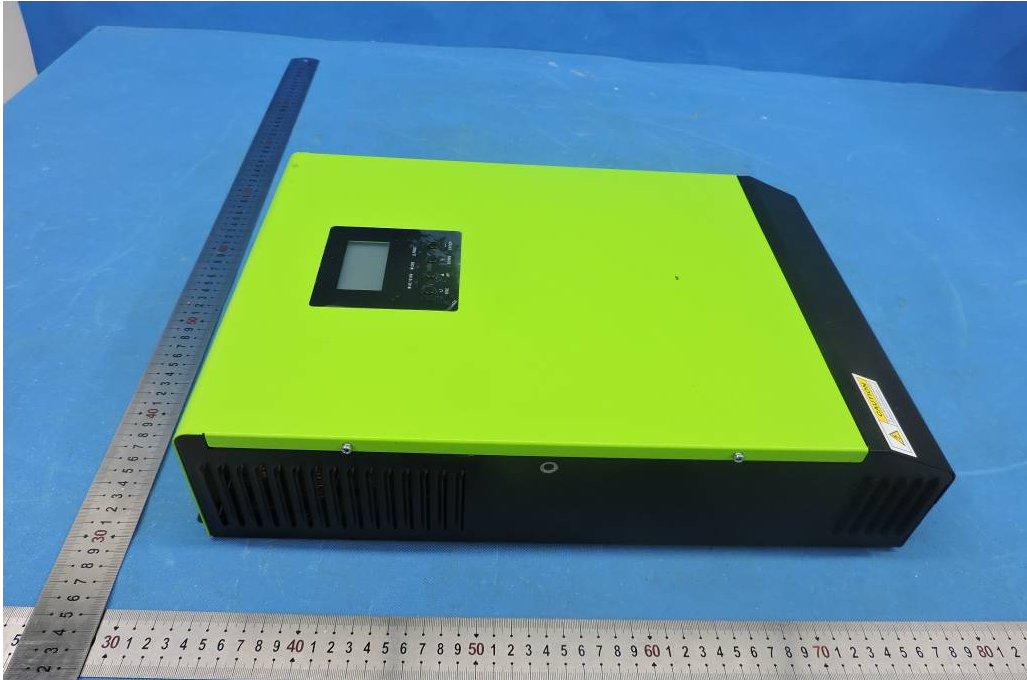

Figure 4
General Appearance of the E.U.T.
M/N: FlinInfini Lite 2kW-24V

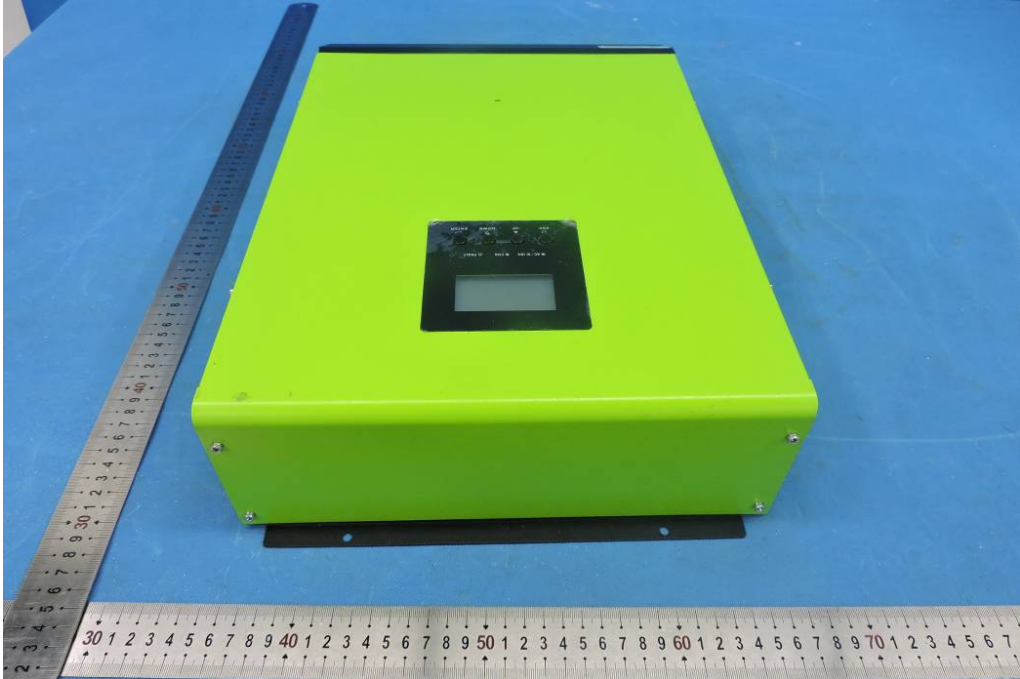

Figure 5
General Appearance of the E.U.T.
M/N: FlinInfini Lite 2kW-24V



Figure 6
General Internal of the E.U.T.
M/N: FlinInfini Lite 2kW-24V



Figure 7
General Appearance of the E.U.T.
M/N: FlinInfini Lite 2kW-24V

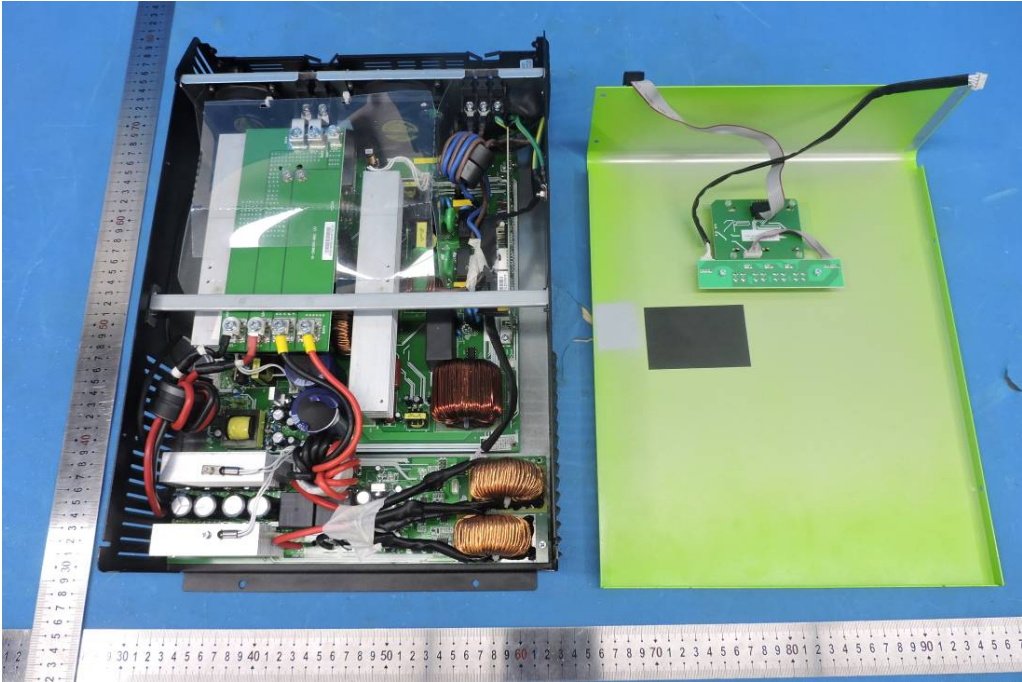

Figure 8
General Appearance of the PCB
M/N: FlinInfini Lite 2kW-24V

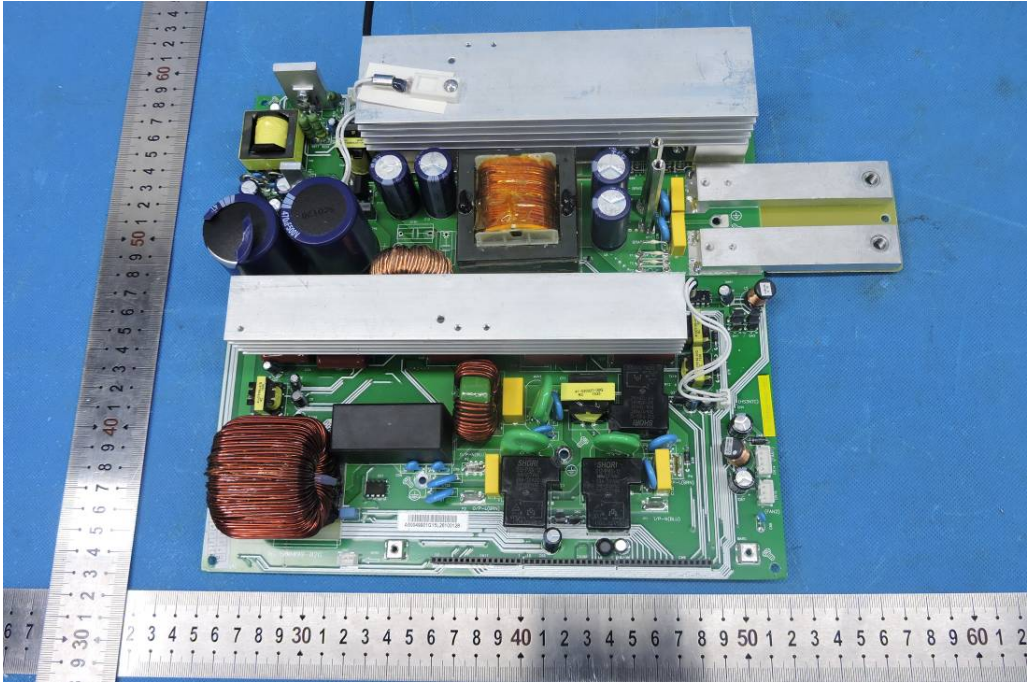

Figure 9
General Appearance of the PCB
M/N: FlinInfini Lite 2kW-24V

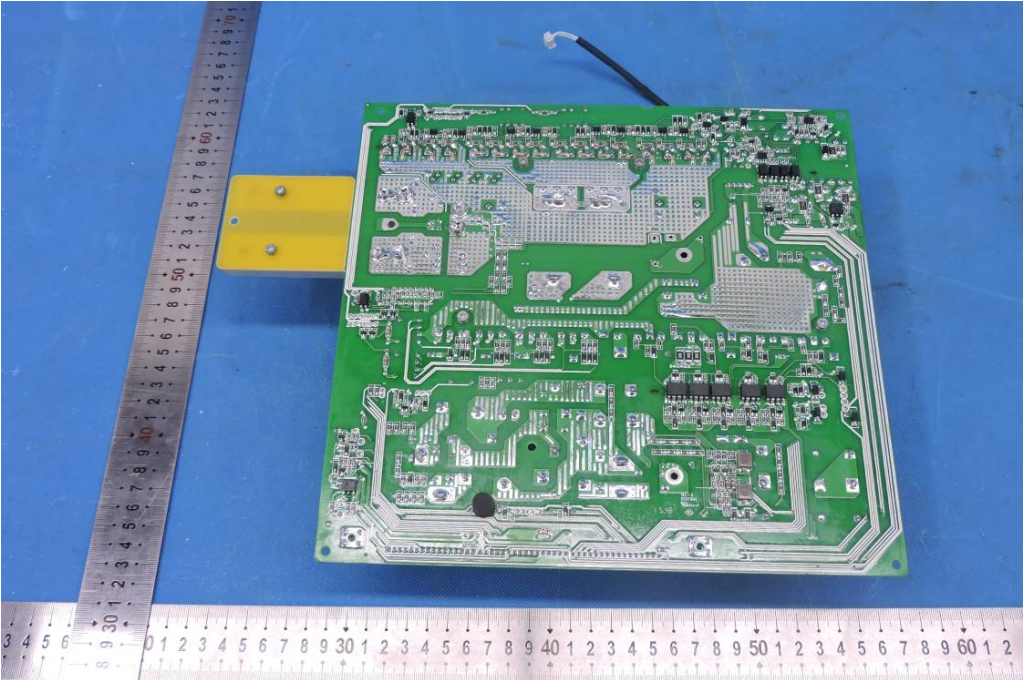

Figure 10
General Appearance of the E.U.T.
M/N: FlinInfini Lite 1kW-12V



Figure 11
General Appearance of the E.U.T.
M/N: FlinInfini Lite 1kW-12V

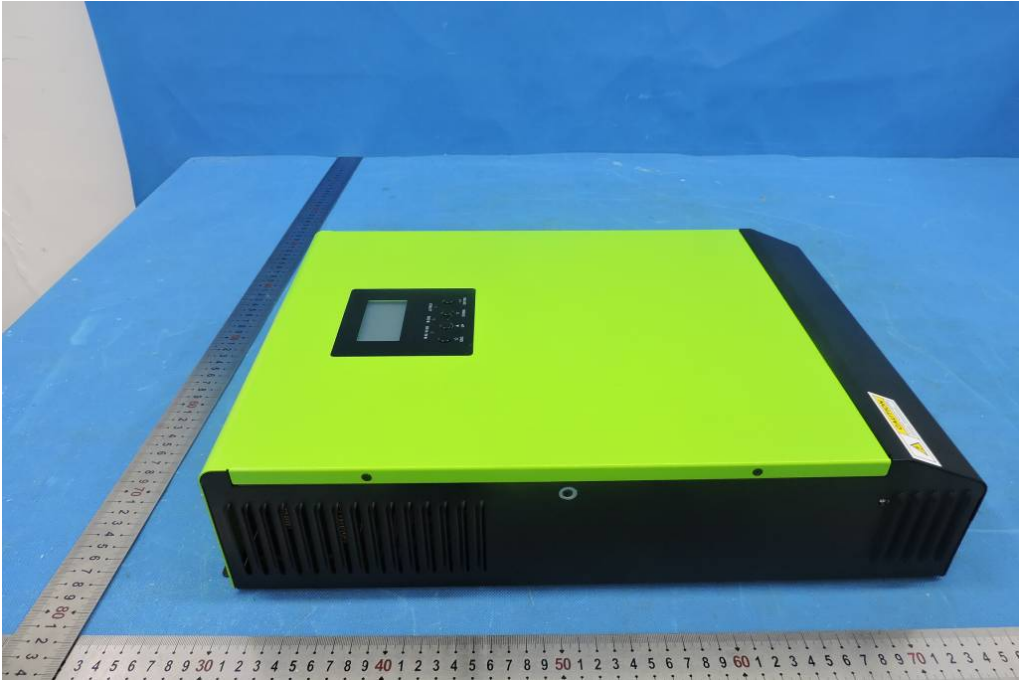

Figure 12
General Appearance of the E.U.T.
M/N: FlinInfini Lite 1kW-12V



Figure 13
General Appearance of the E.U.T.
M/N: FlinInfini Lite 1kW-12V

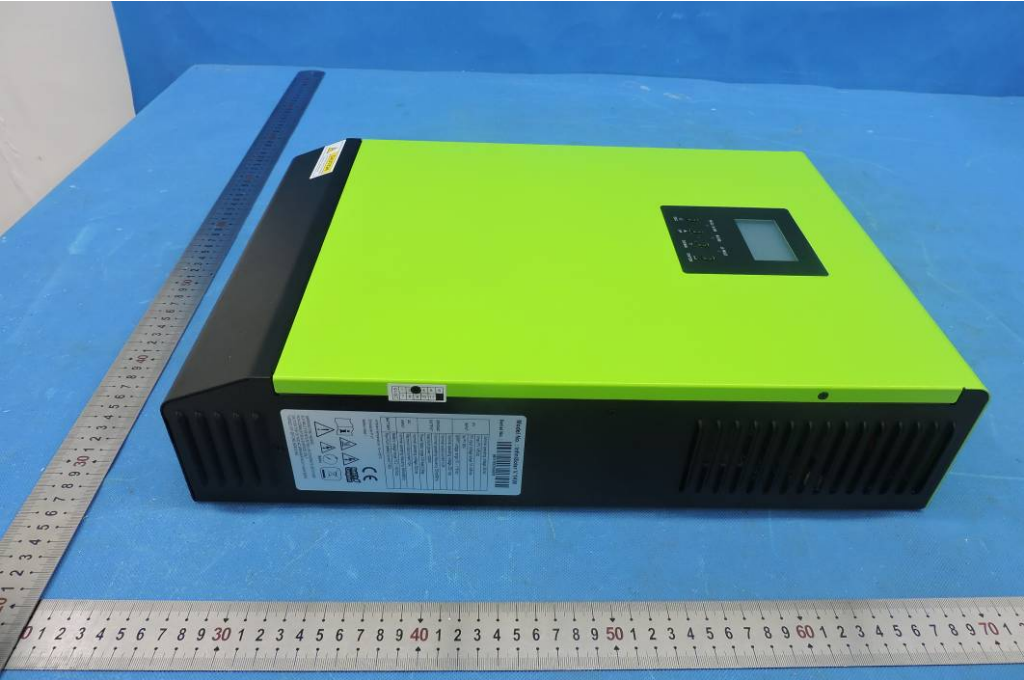

Figure 14
General Appearance of the E.U.T.
M/N: FlinInfini Lite 1kW-12V



Figure 15
General Internal of the E.U.T.
M/N: FlinInfini Lite 1kW-12V

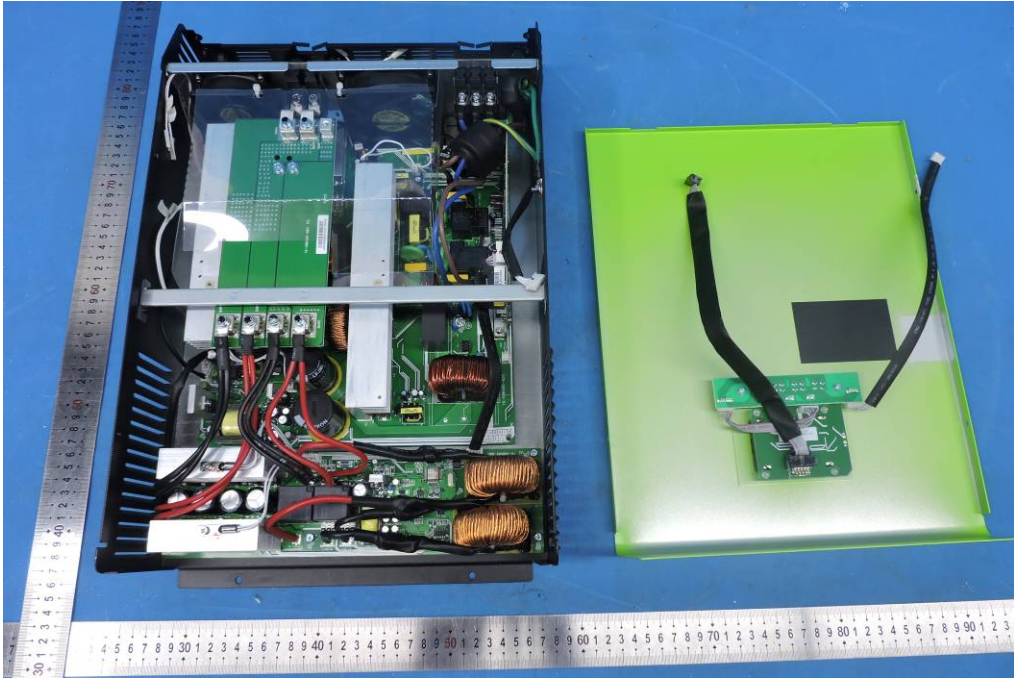

Figure 16
General Appearance of the PCB
M/N: FlinInfini Lite 1kW-12V

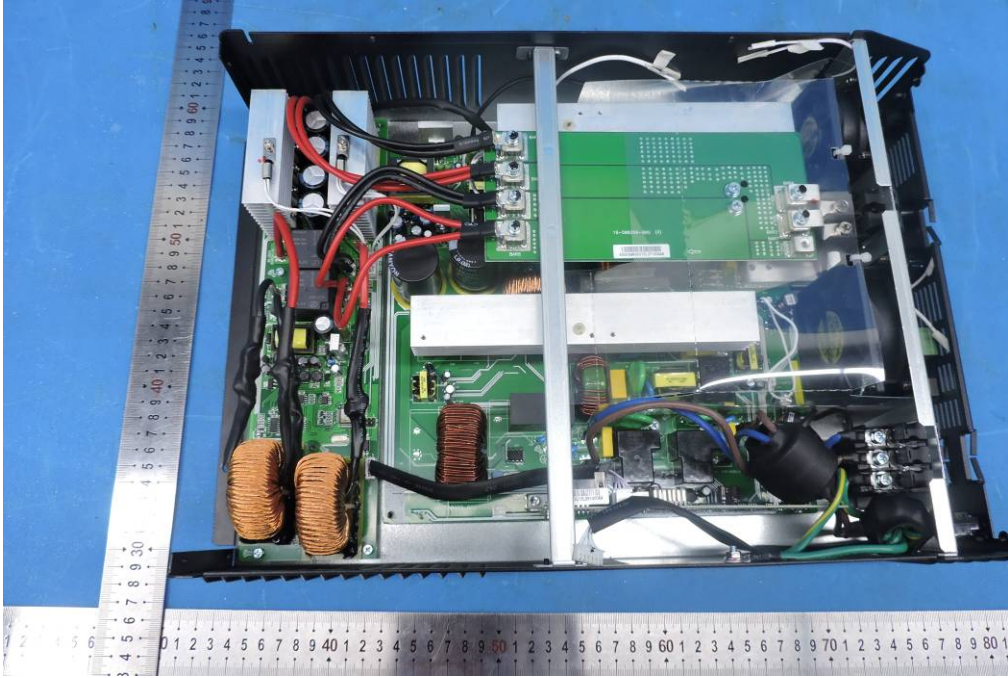

Figure 17
General Appearance of the PCB
M/N: FlinInfini Lite 1kW-12V

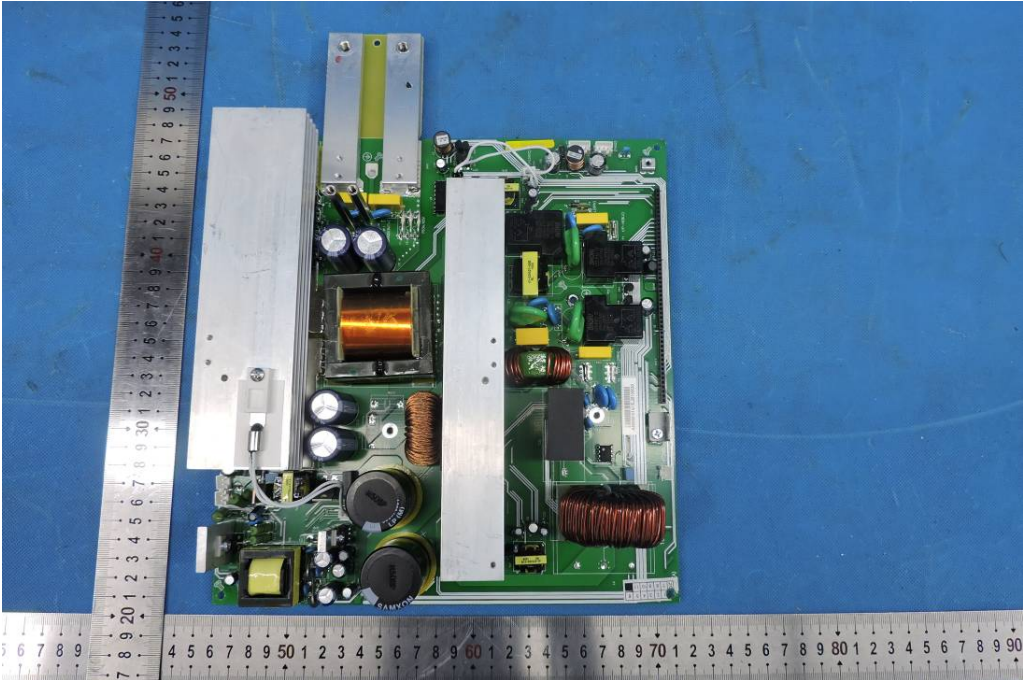

Figure 18
General Appearance of the PCB
M/N: FlinInfini Lite 1kW-12V

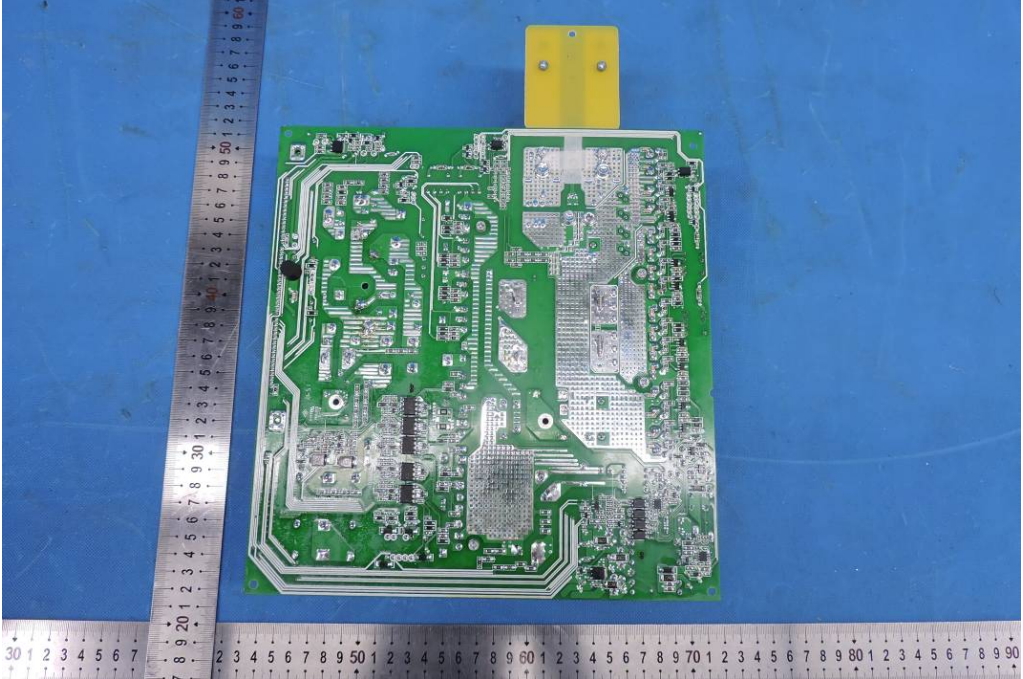

Figure 19
General Appearance of the PCB

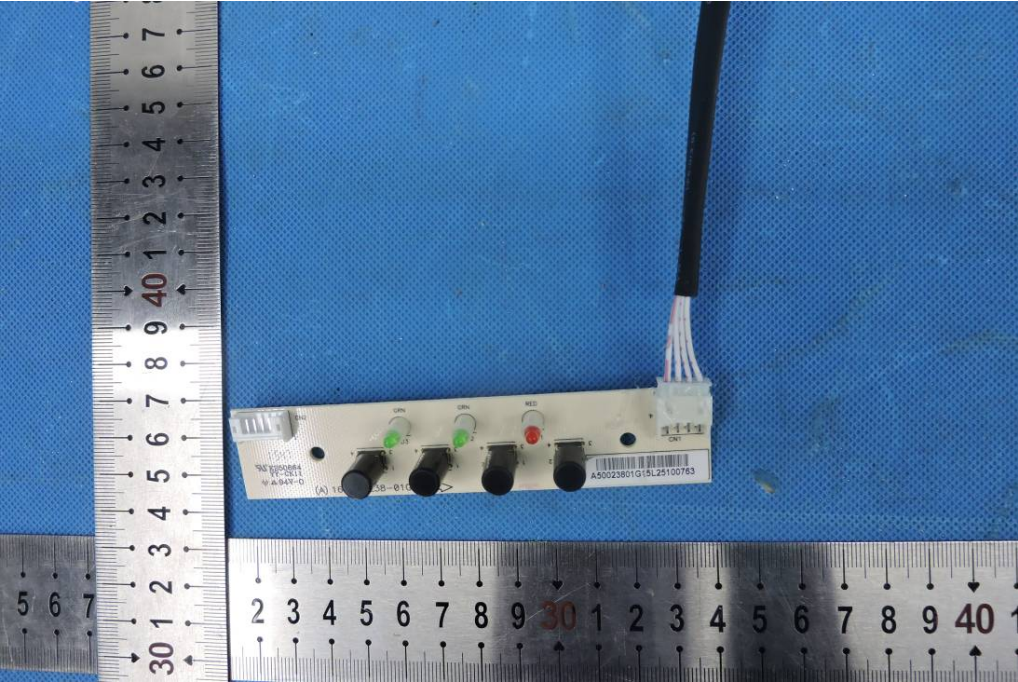

Figure 20
General Appearance of the PCB

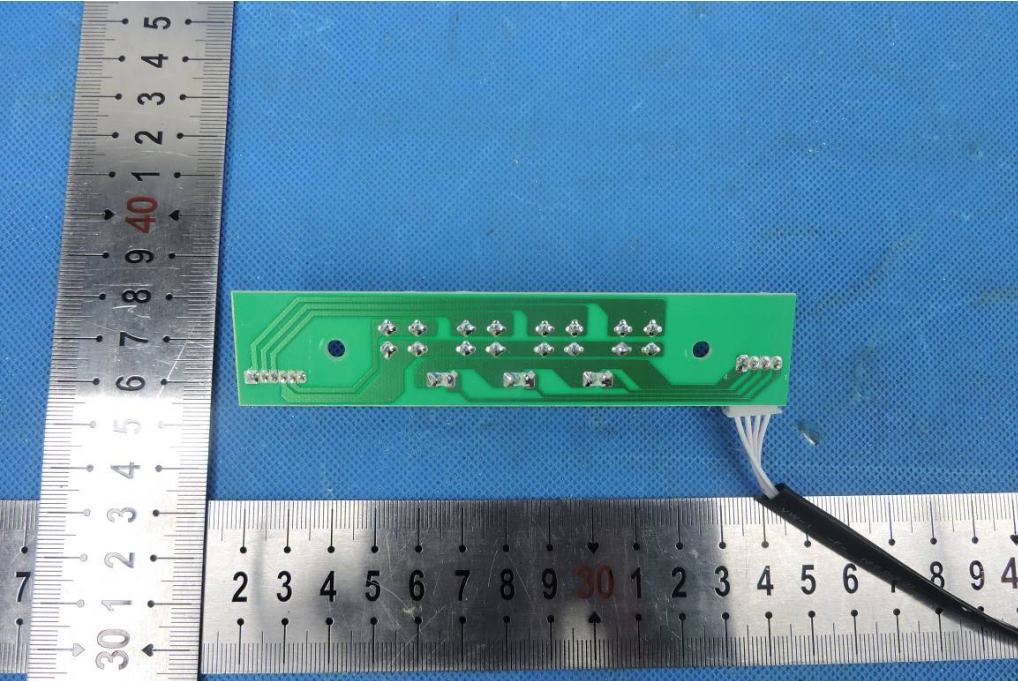

Figure 21
General Appearance of the PCB

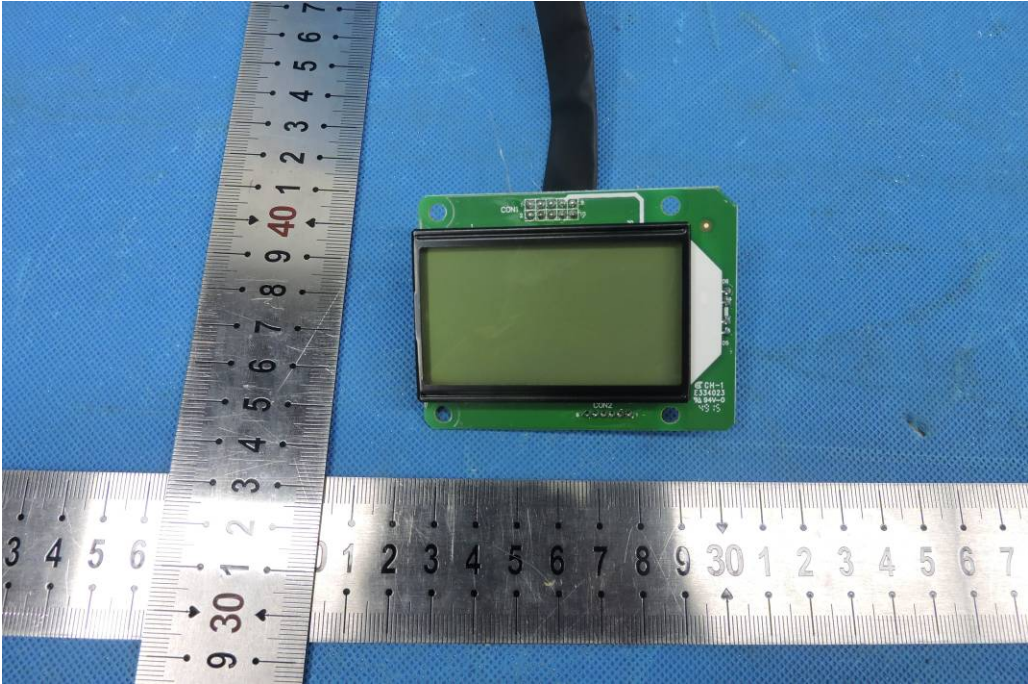

Figure 22
General Appearance of the PCB

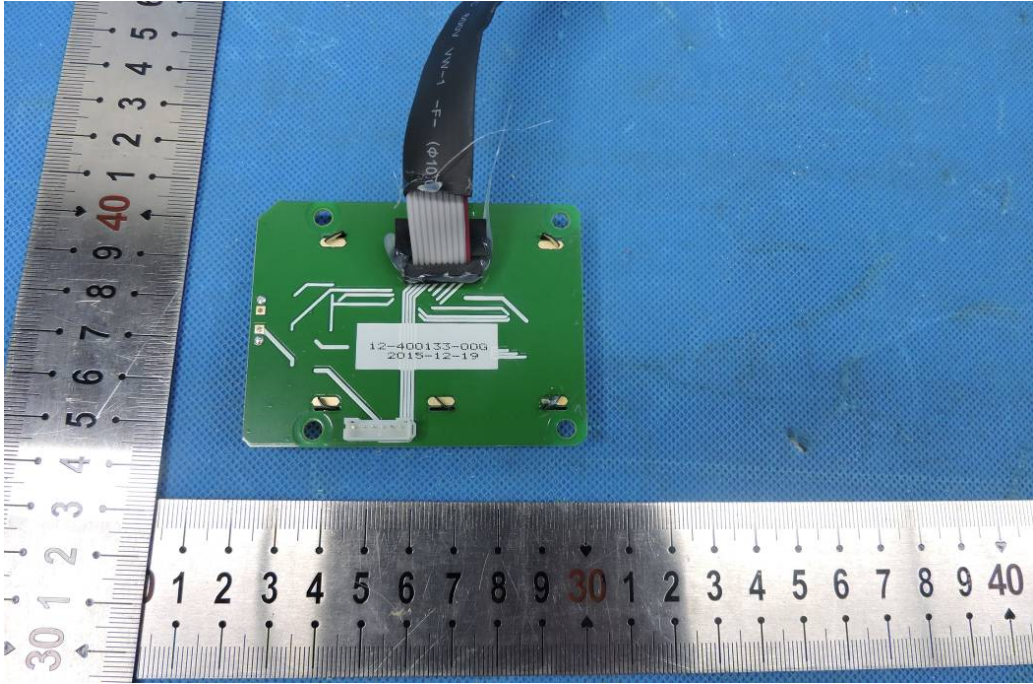

Figure 23
General Appearance of the PCB

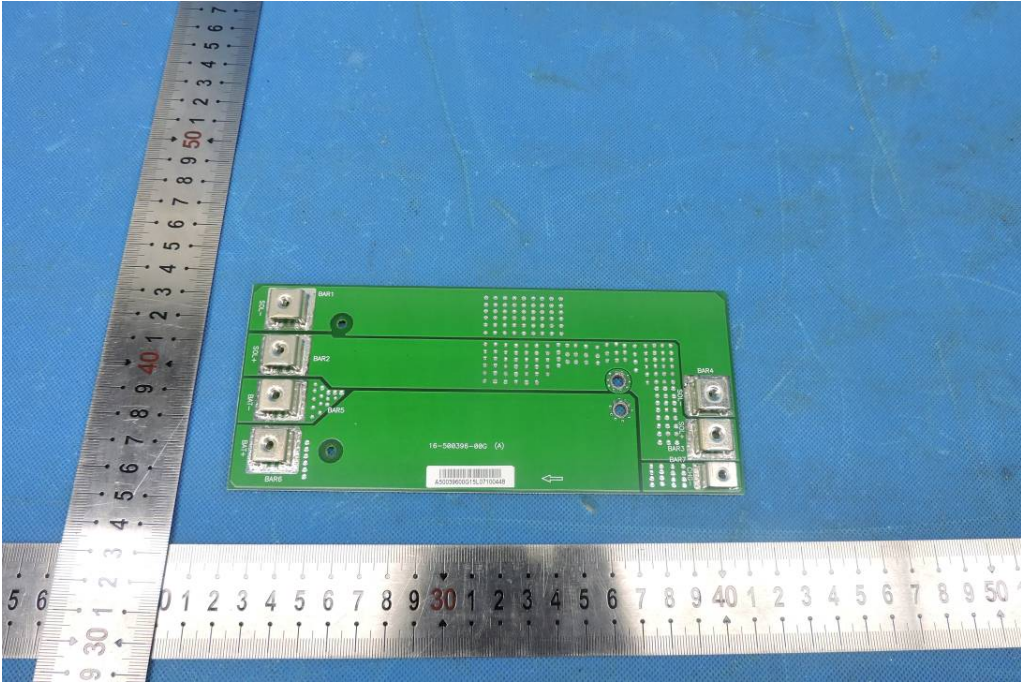

Figure 24
General Appearance of the PCB

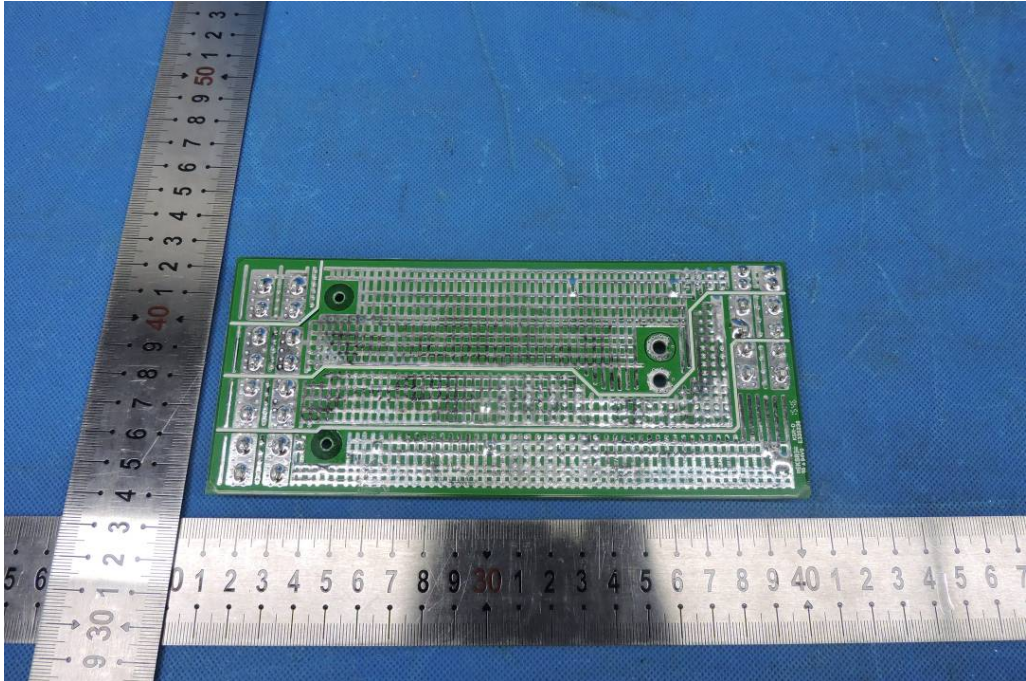

Figure 25
General Appearance of the PCB

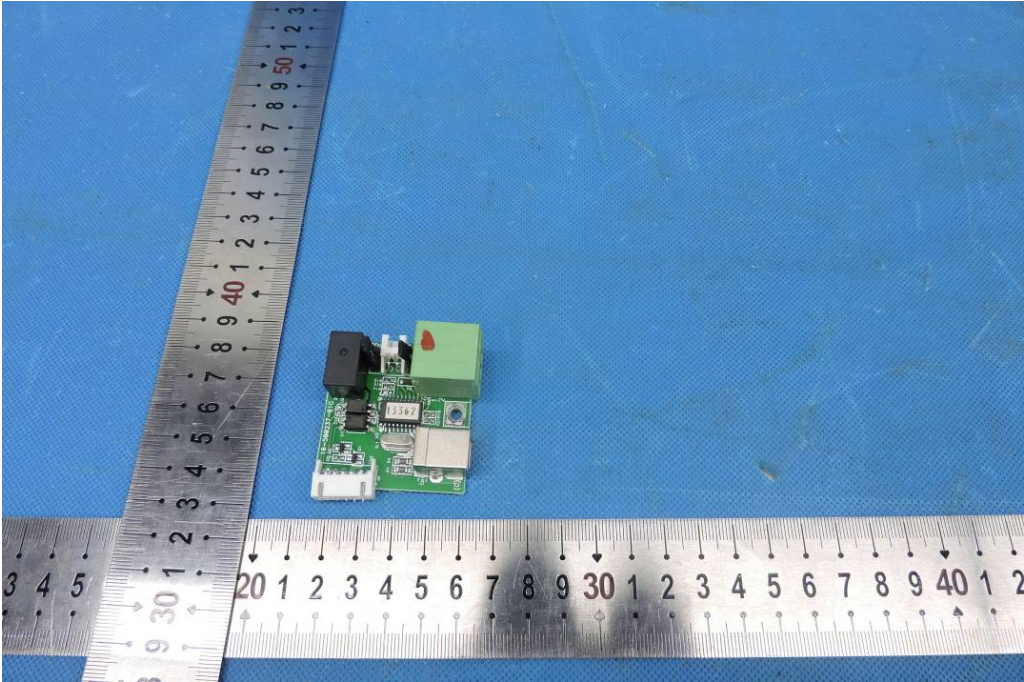

Figure 26
General Appearance of the PCB

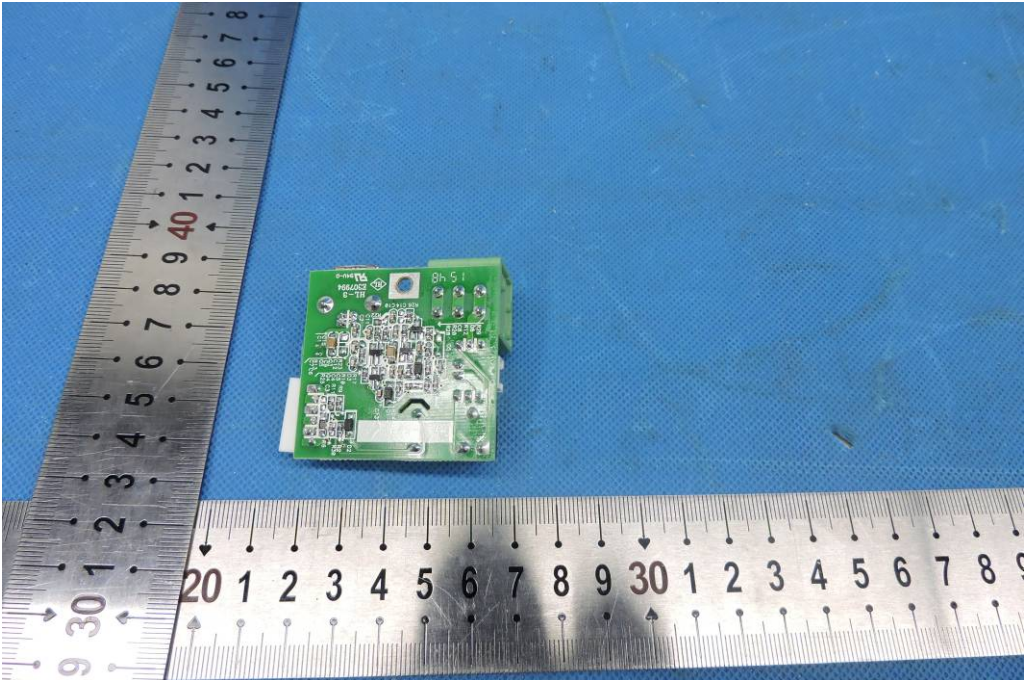

Figure 27
General Appearance of the PCB

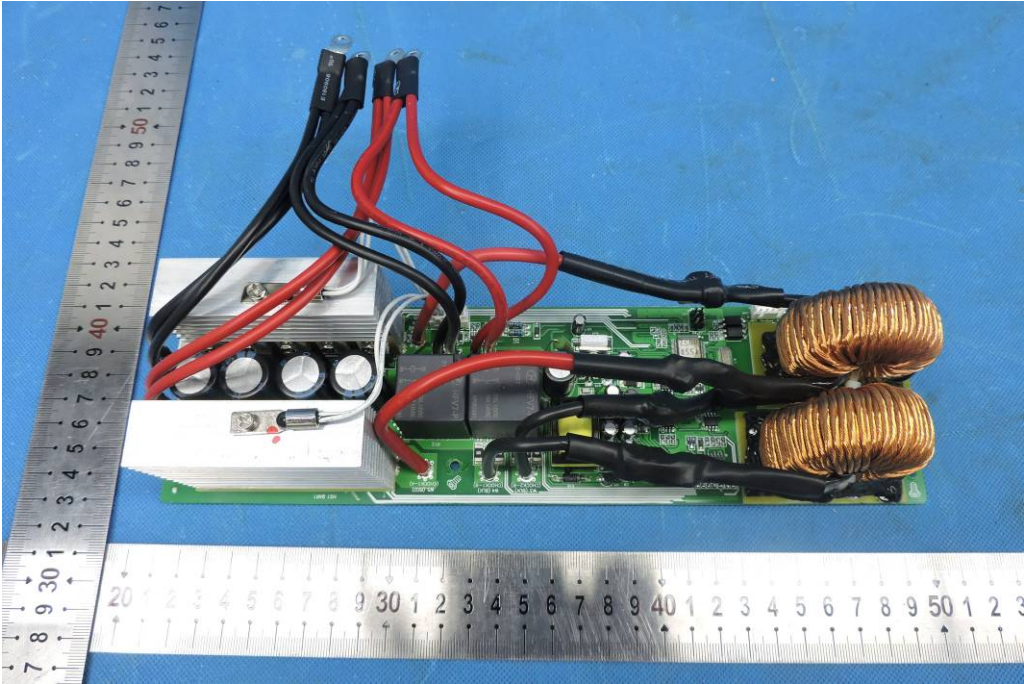

Figure 28
General Appearance of the PCB

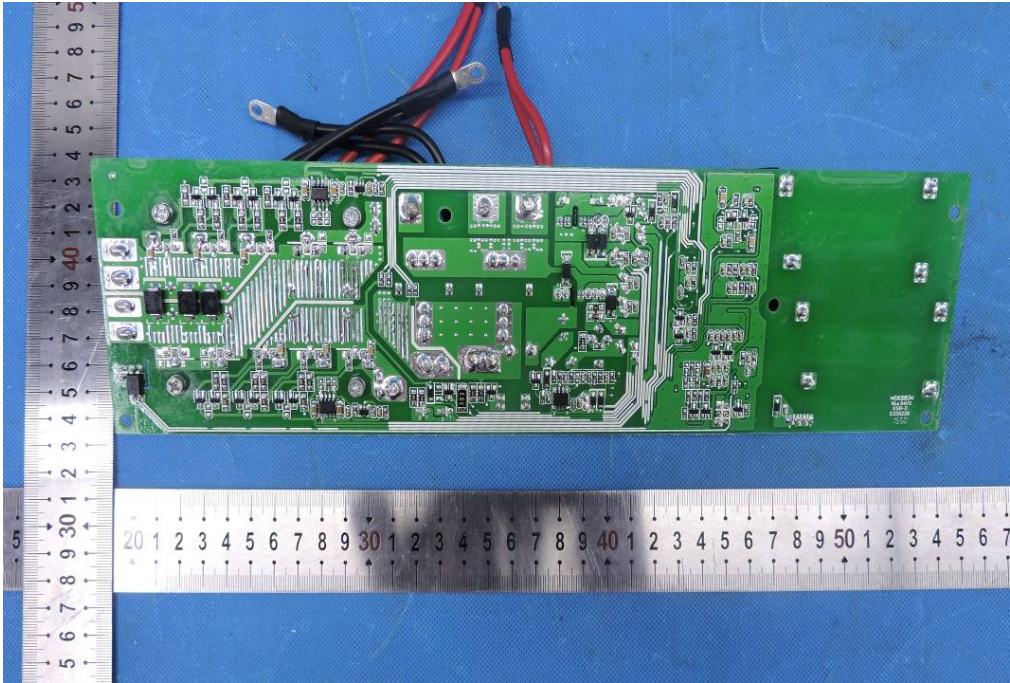

Figure 29
General Appearance of the PCB

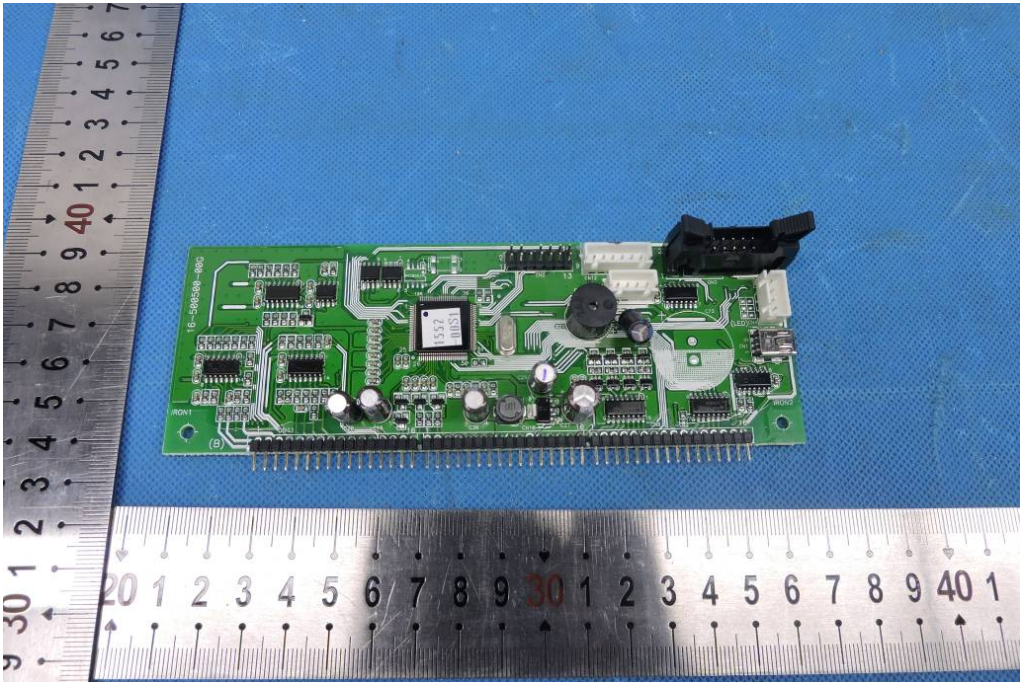
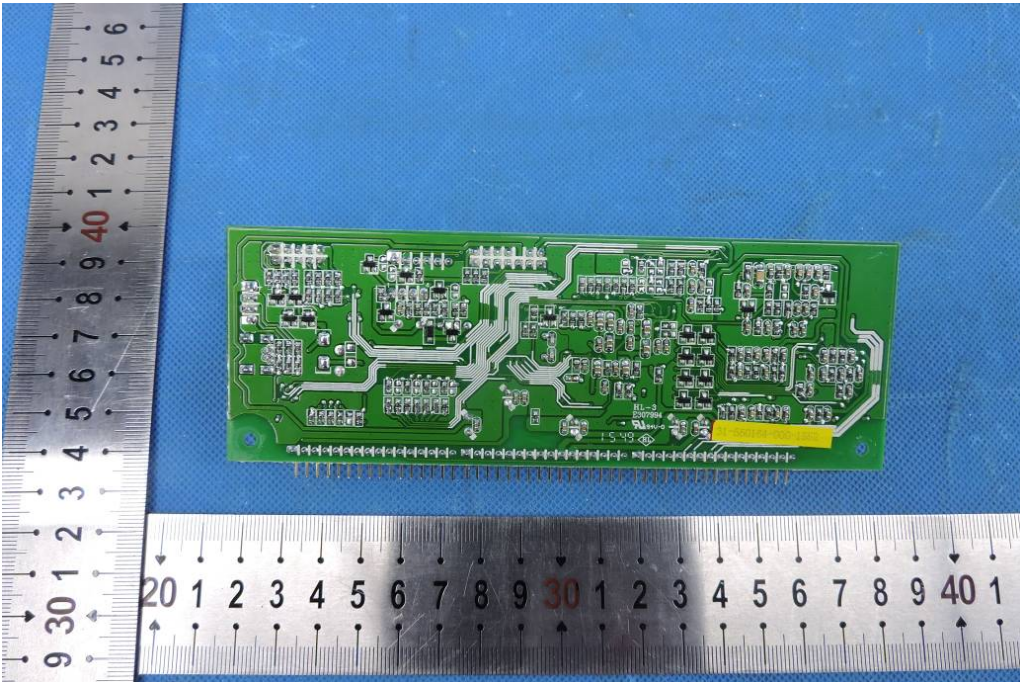

Figure 30
General Appearance of the PCB



---End---